

Art libre

Copyleft Attitude

Cette notice est en licence libre, vous êtes libre de l'utiliser et de la modifier (voir modalités en dernière page), d'exercer votre esprit critique et de nous faire part de vos remarques constructives.

Buffet de cuisine

TEMPS DE RÉALISATION

heures

COÛT INDICATIF

euros

DIFFICULTÉ



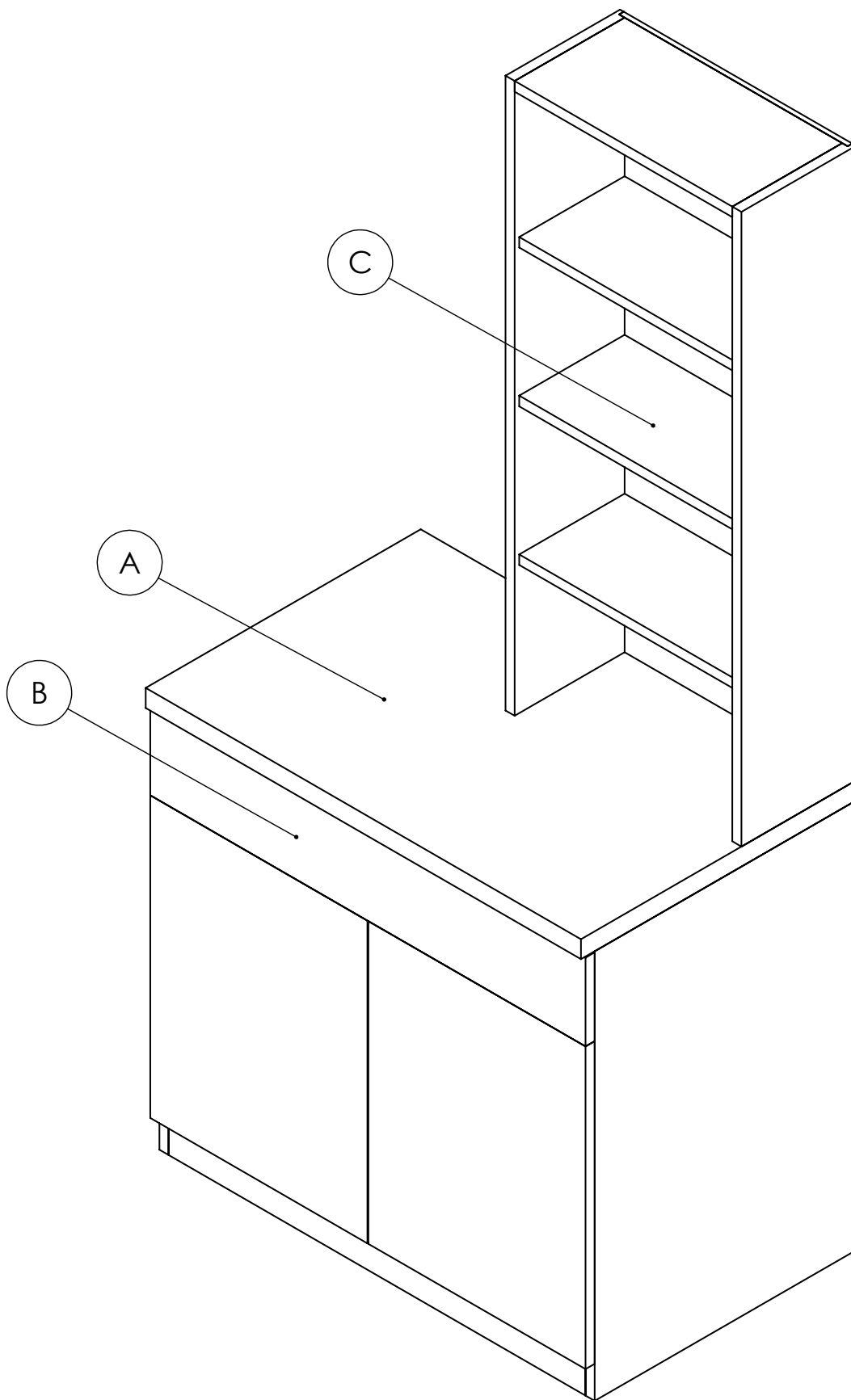

ANNEXE A
Vue d'ensemble

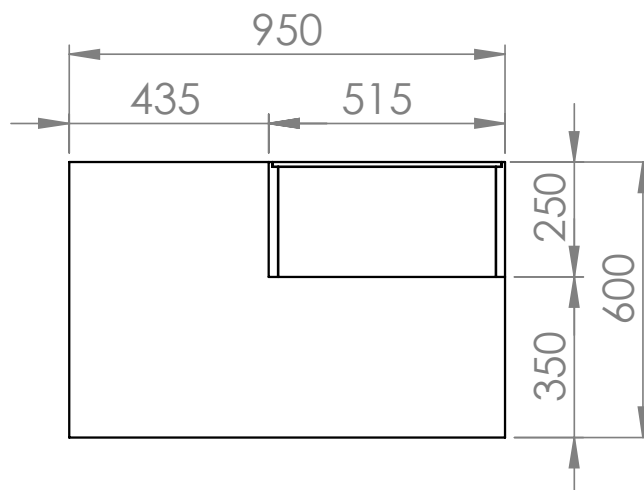
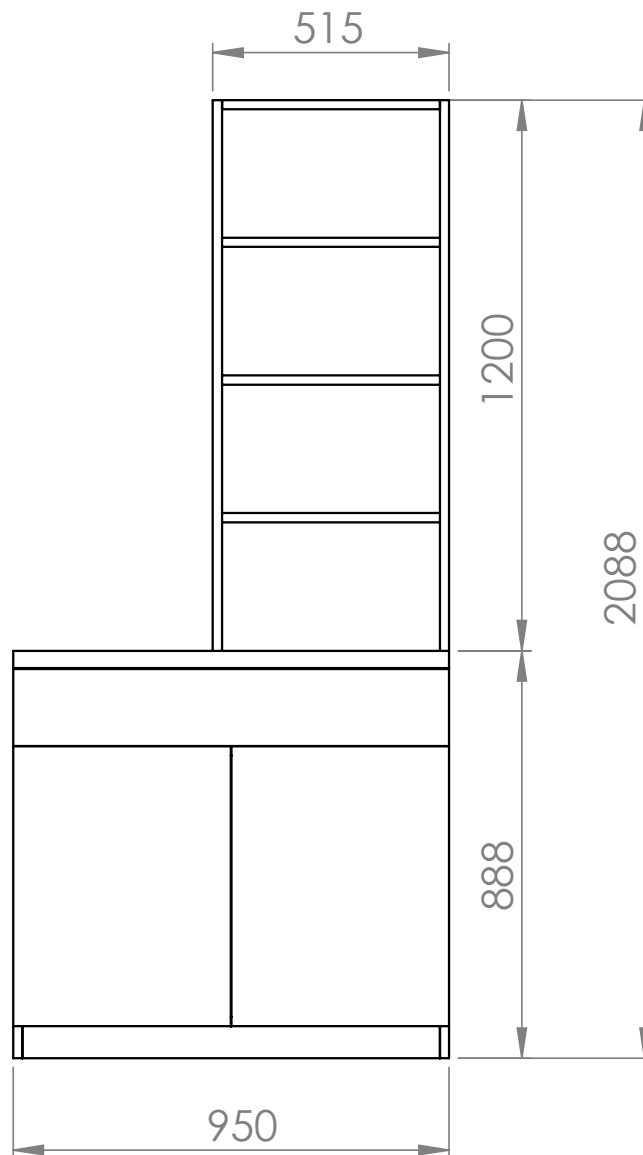

ANNEXE B
 Vue d'ensemble

Nombre	Nom des pièces	Matériaux	Description	Epaisseur (mm)	Largeur (mm)	Longueur (mm)	Commentaire
	A						
2	A1	stratifié blanc	A1 coté	20mm	570	850	
1	A2	stratifié blanc	A2 dessus	20mm	560	910	
2	A3	tripli	A3 plinthes	20mm	70	910	
1	A4	stratifié blanc	A4 das	20mm	560	910	
1	A5	stratifié blanc	A5 fond	10mm	780	910	
2	A6	contreplaqué t	A6 étagère	20mm	445	560	cf vue de détail
1	A7	stratifié blanc	A7 milieu	20mm	570	560	
1	A8	stratifié blanc	A8 rendort tiroir	20mm	432	570	
2	A9	stratifié blanc	A9 portes	20mm	474	610	
2	A10	Sapin	A10 tasseau	20mm	20	570	
1	A11	Bois massif	A11 plan de travail	~38mm	600	950	

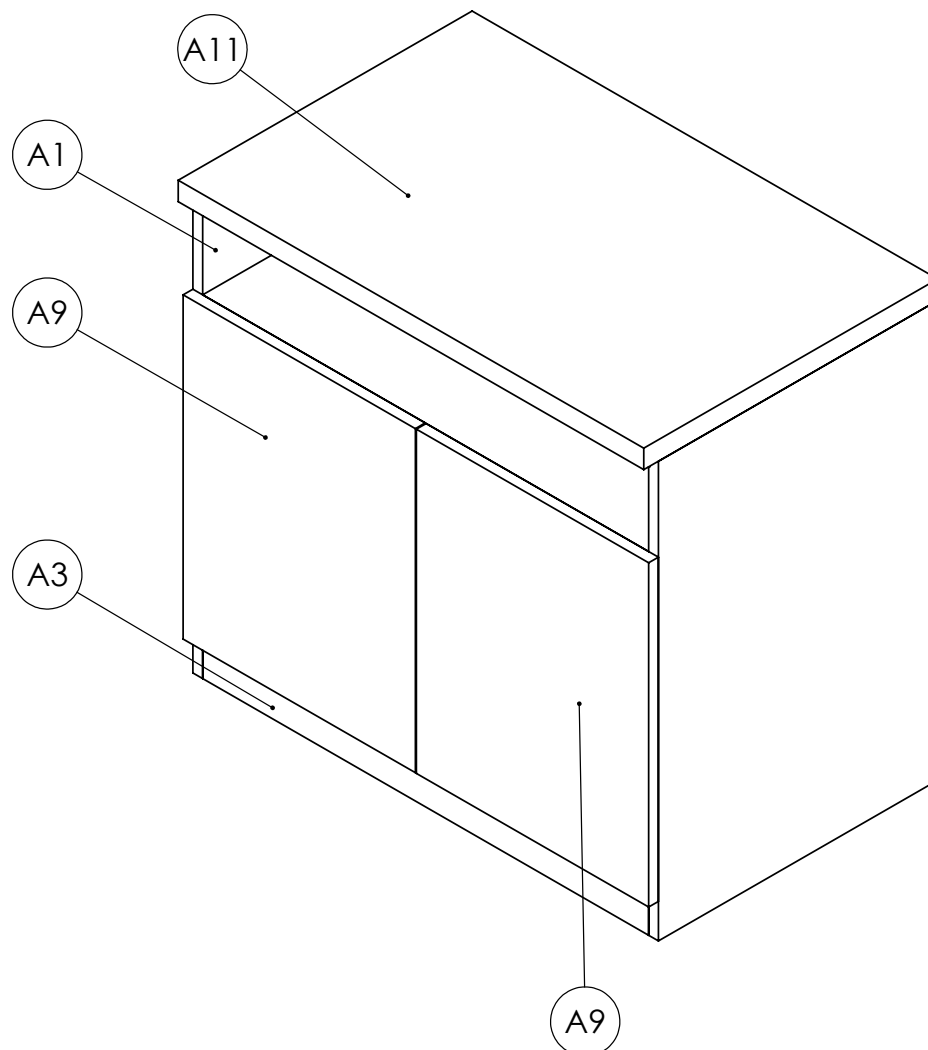

ANNEXE C

Meuble A - Nomenclature

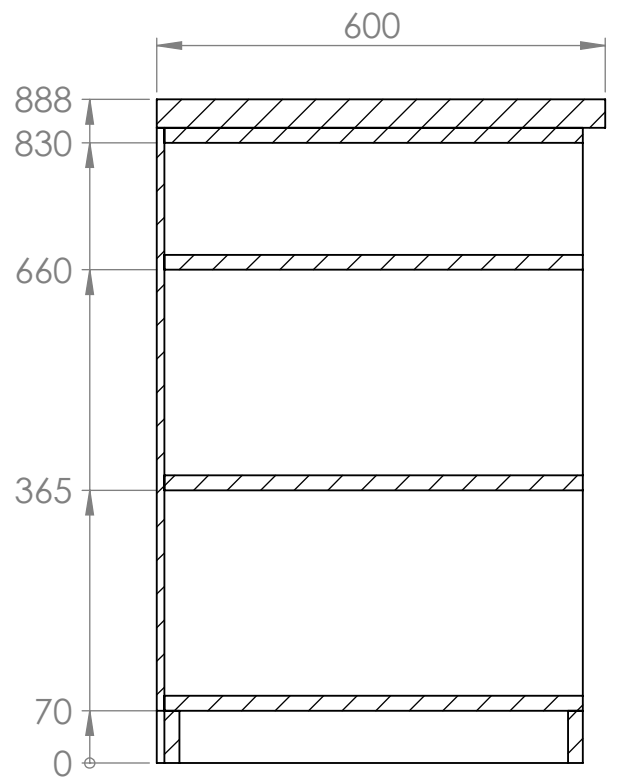
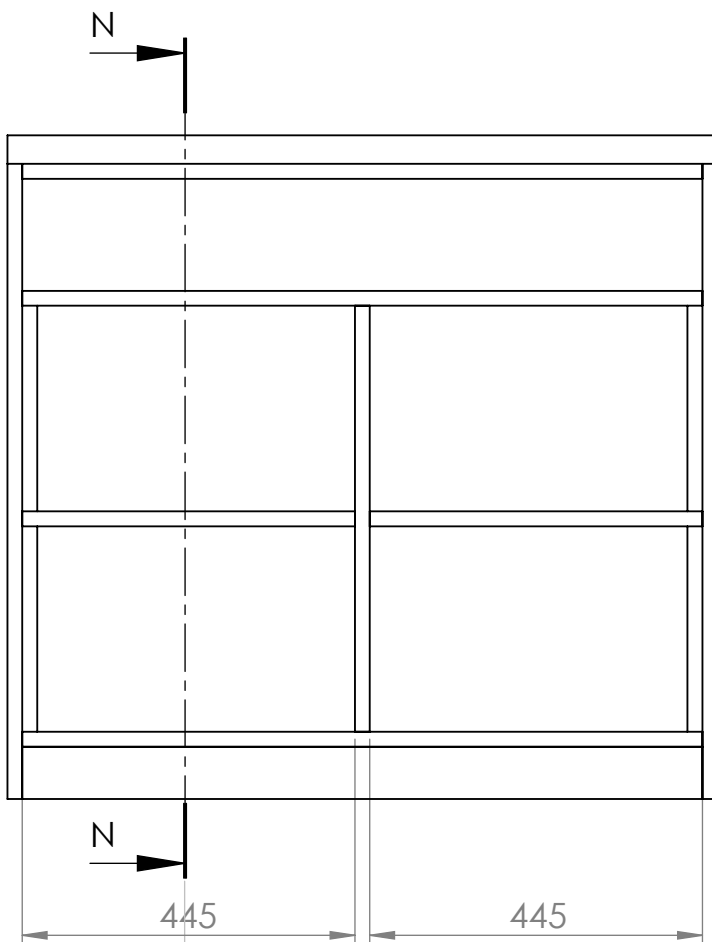
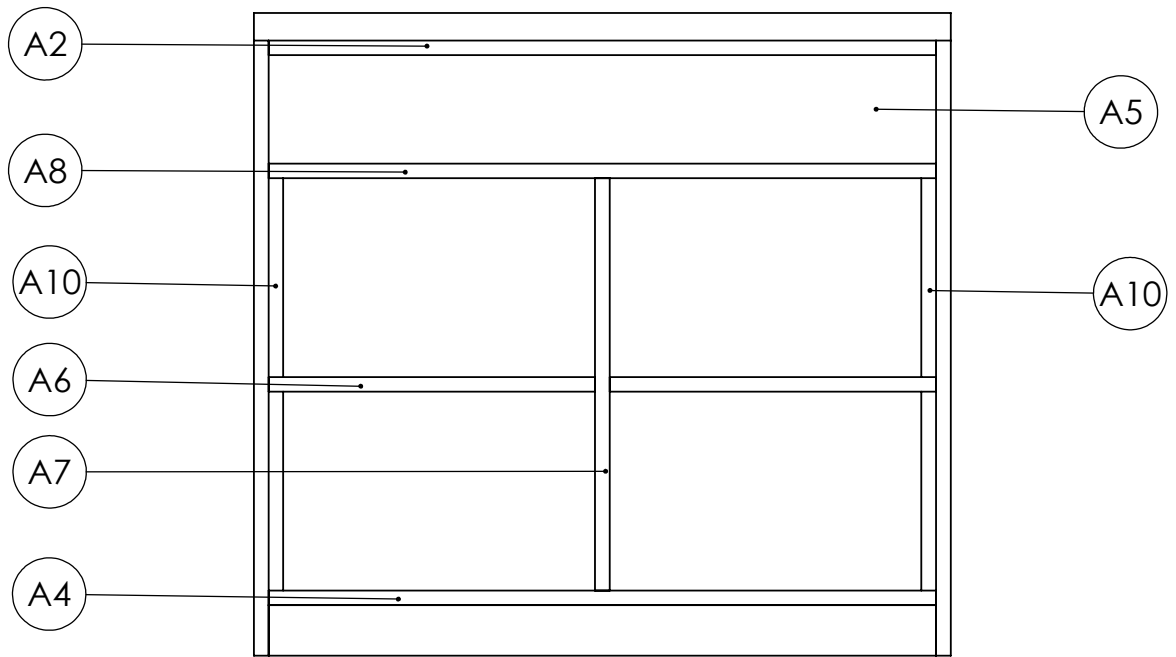

COUPE N-N

ANNEXE D
Meuble A - Élévation et coupe

A6
1

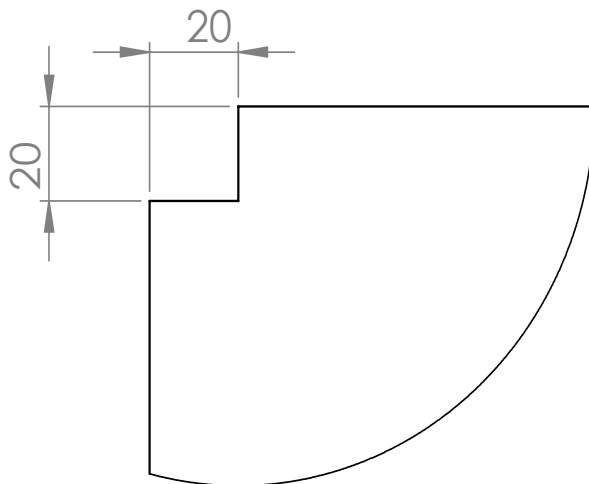
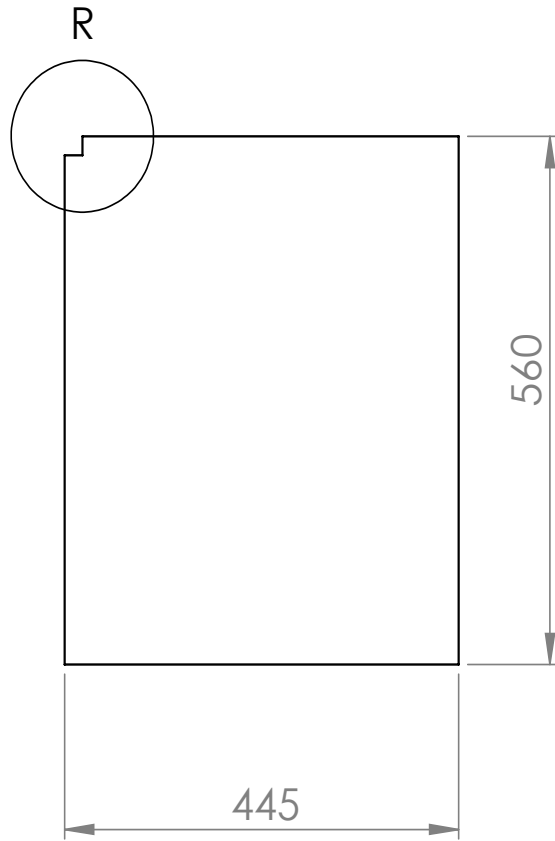

ANNEXE E
Meuble A - Pièce usinée

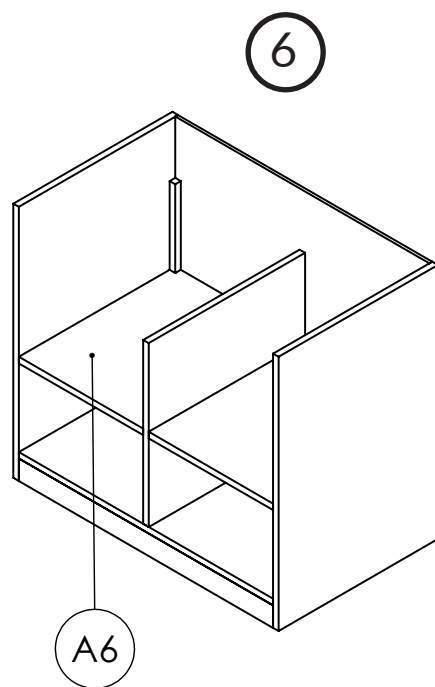
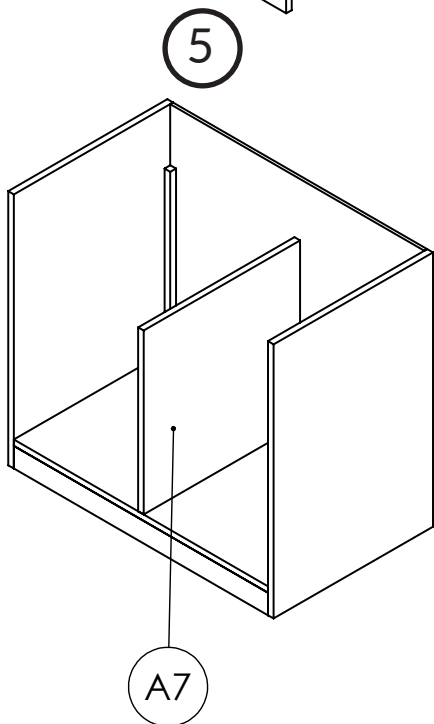
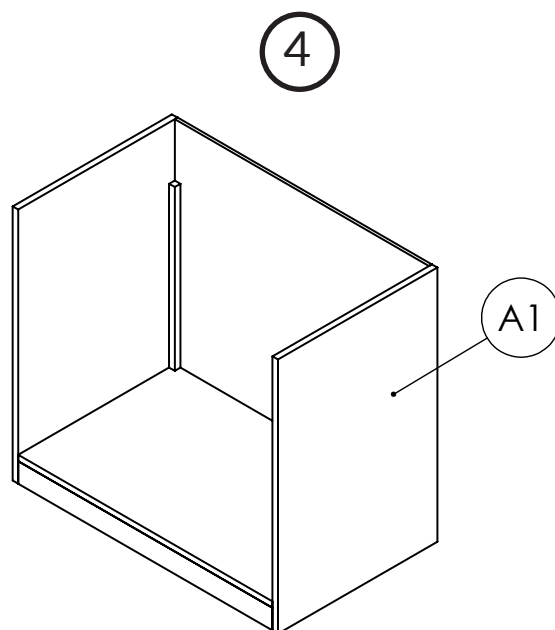
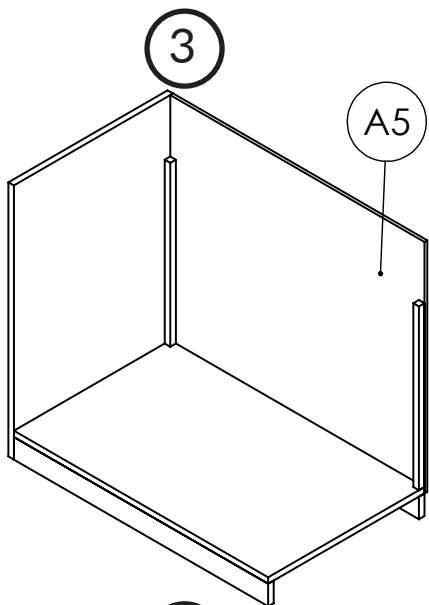
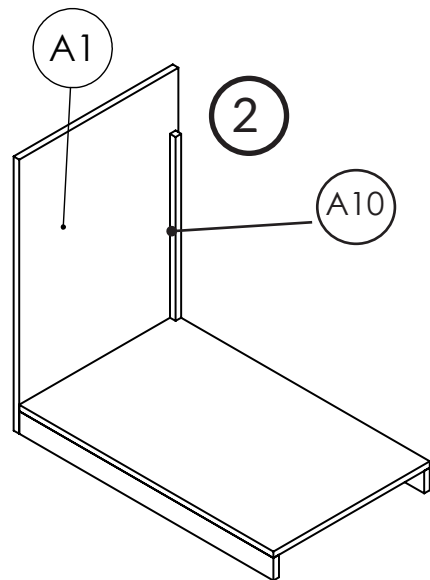
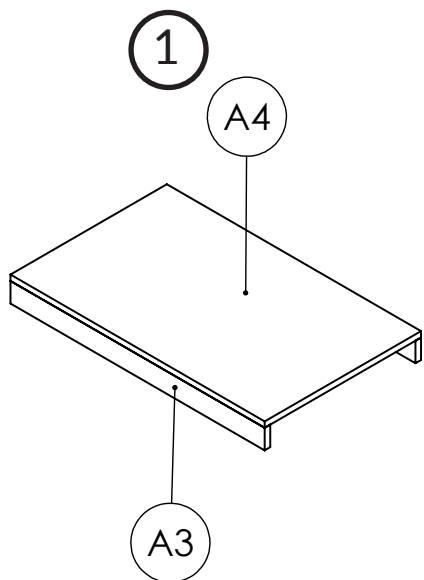

ANNEXE F
Meuble A - Pas à pas

7

A8

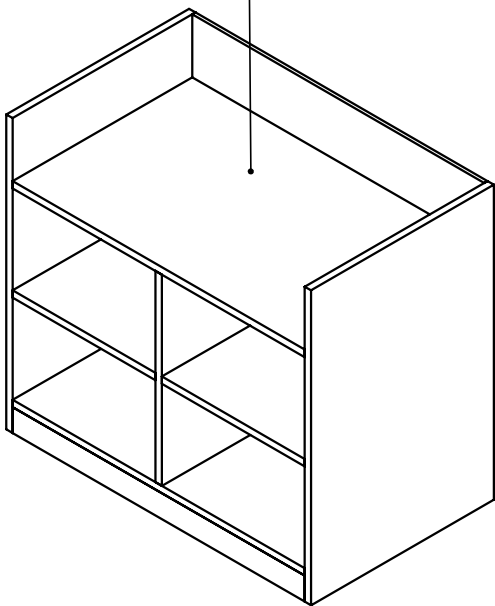

8

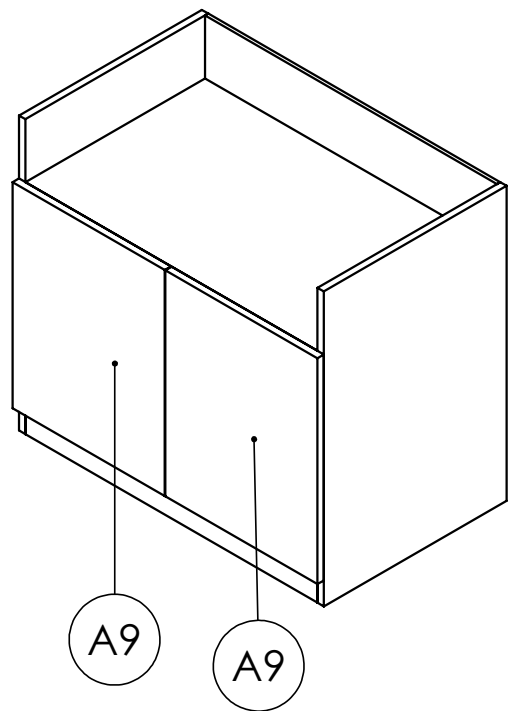

9

A2

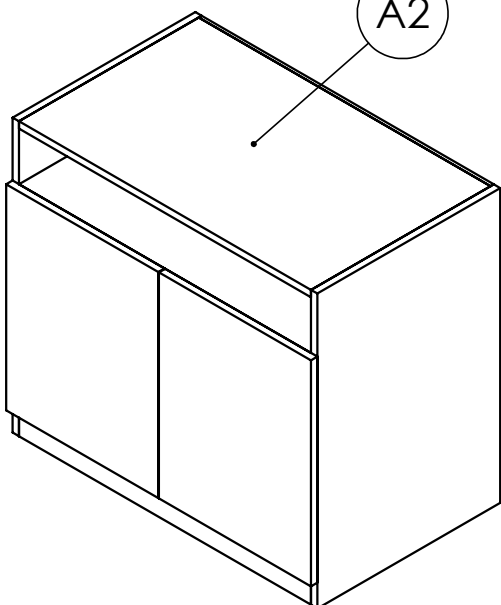

10

A11

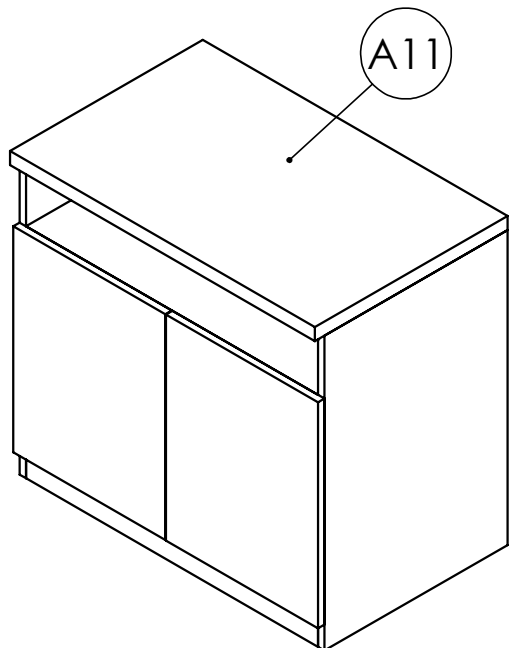

ANNEXE G
Meuble A - Pas à pas

Nombre	Nom des pièces	Matériaux	Description	Epaisseur (mm)	Largeur (mm)	Longueur (mm)	Commentaire
	B						
1	B1	stratifié blanc	B1 coté	20mm	140	515	cf vue de détail
1	B2	stratifié blanc	B2 coté	20mm	140	515	cf vue de détail
1	B3	stratifié blanc	B3 devant caché	20mm	140	885	cf vue de détail
1	B4	stratifié blanc	B4 arrière	20mm	140	885	
1	B5	stratifié blanc	B5 devant	20mm	168	950	
1	B6	contreplaqué bois	B6 fond	10mm	531	861	
1	B7	stratifié blanc	B7 intercalaire	20mm	114	515	

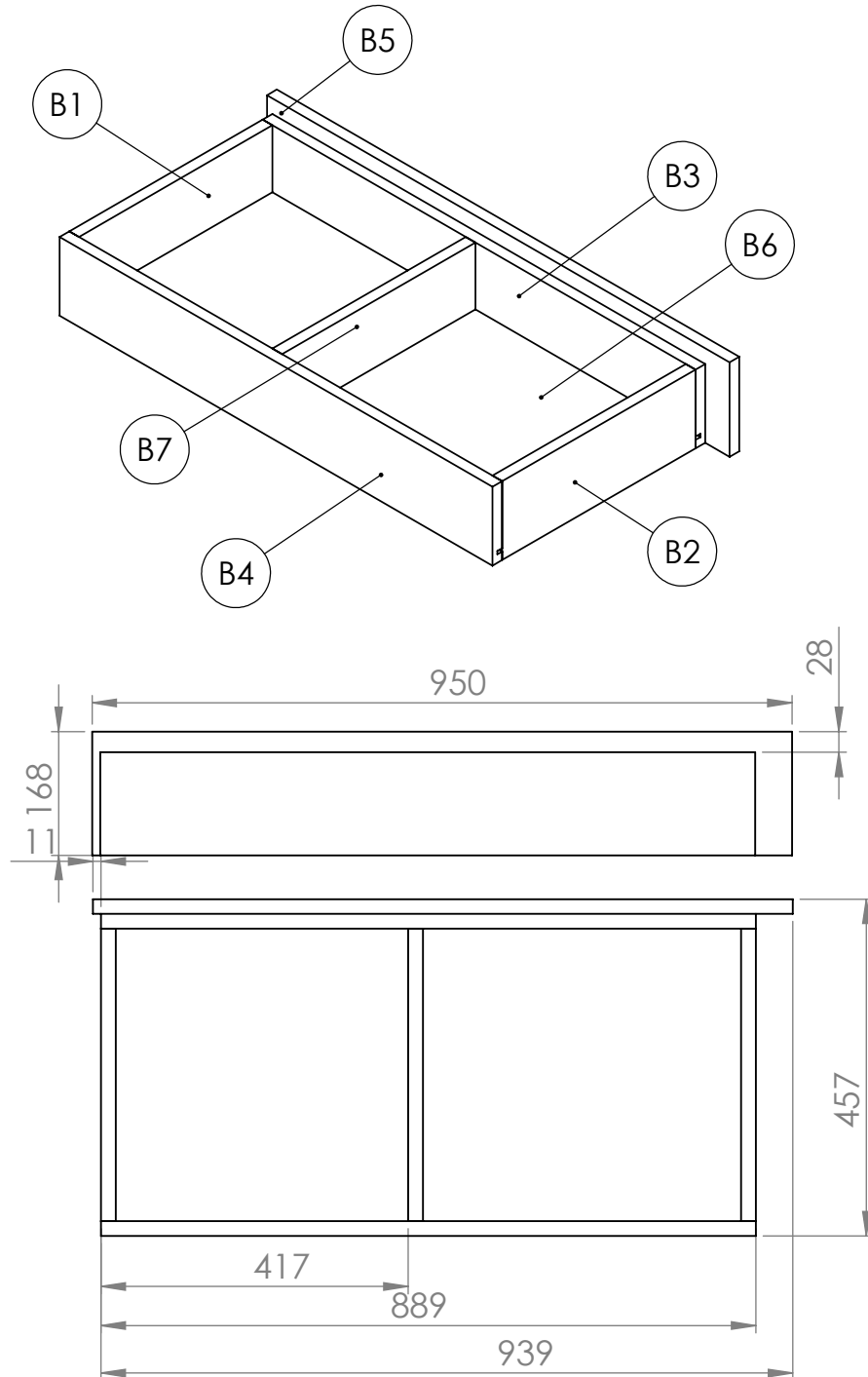

ANNEXE H
Meuble B - Nomenclature

B3
2

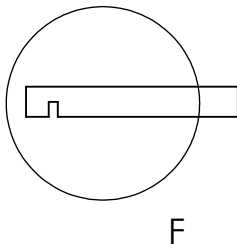
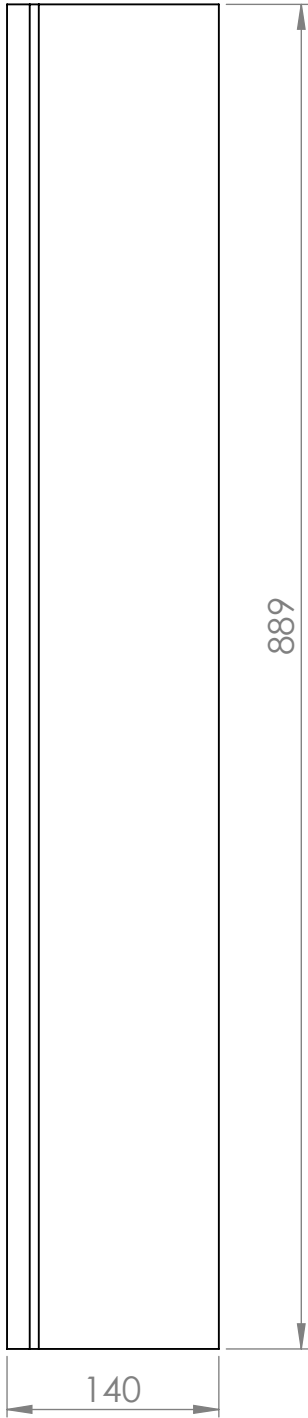

B1
1

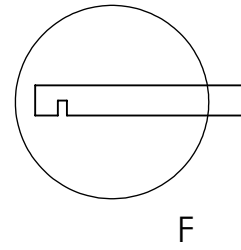
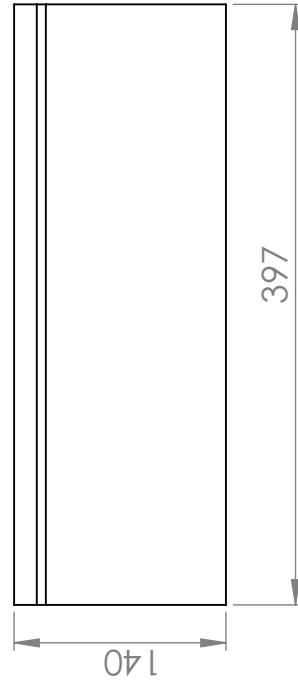

même détail pour B2

DÉTAIL F

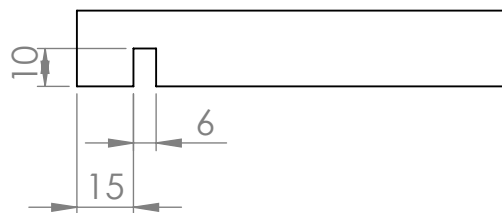

ANNEXE I
Meuble B - Pièces usinées

Nombre	Nom des pièces	Matériaux	Description	Épaisseur (mm)	Largeur (mm)	Longueur (mm)	Commentaire
	C						
2	C1	stratifié blanc	C1 coté	20mm	250	1200	cf vue de détail
1	C2	stratifié blanc	C2 dessus	20mm	240	475	
3	C3	stratifié blanc	C3 étagère	20mm	230	475	
1	C4	stratifié blanc	C4 fond	10mm	499	1200	

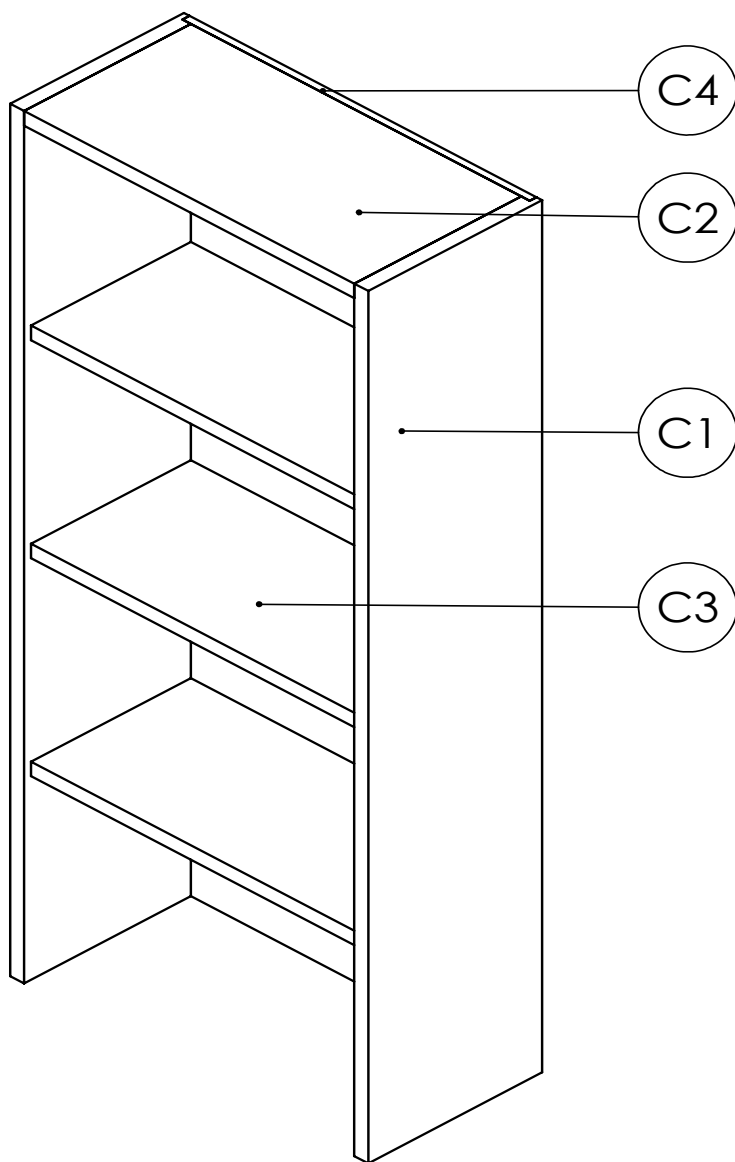

ANNEXE O

Meuble C - Nomenclature

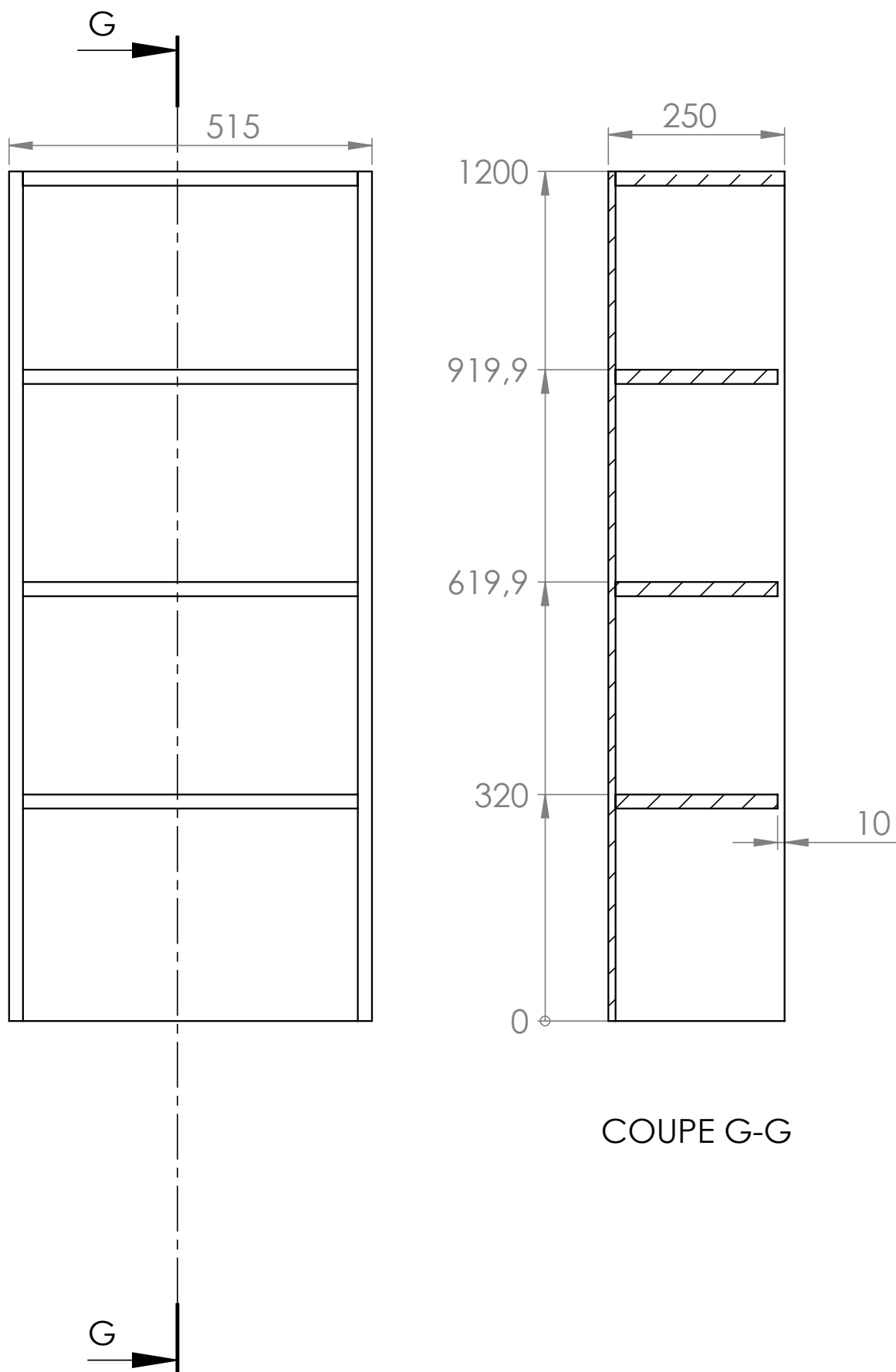

ANNEXE P
 Meuble C - Élévation et coupe

C1
2

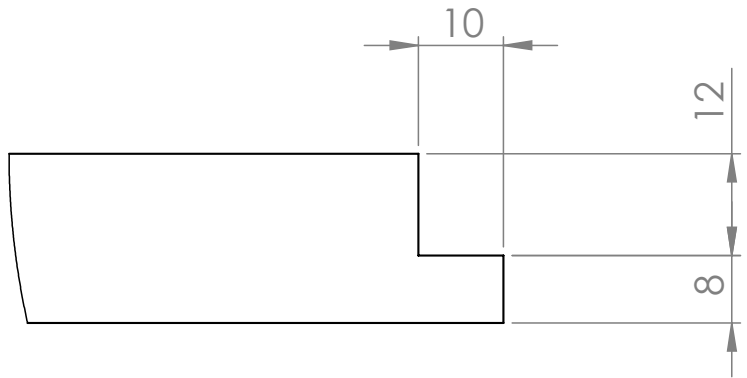
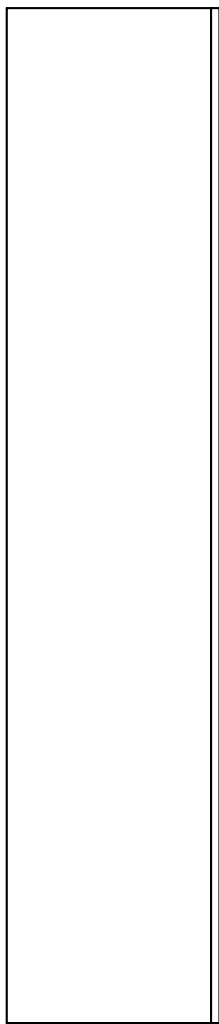
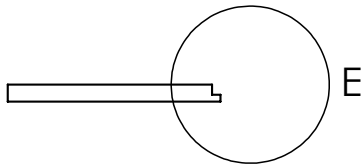

DÉTAIL E

ANNEXE Q

Meuble C - Pièce usinée

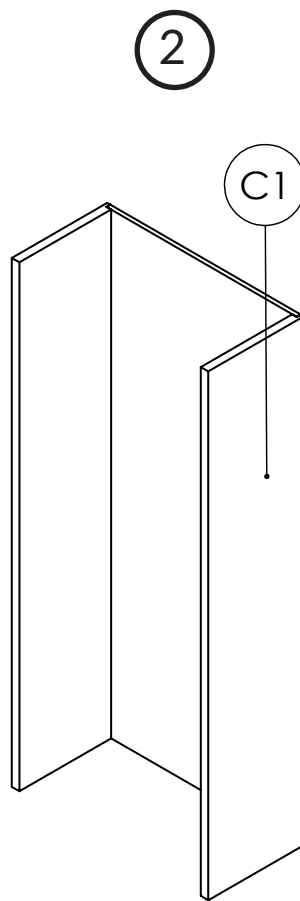
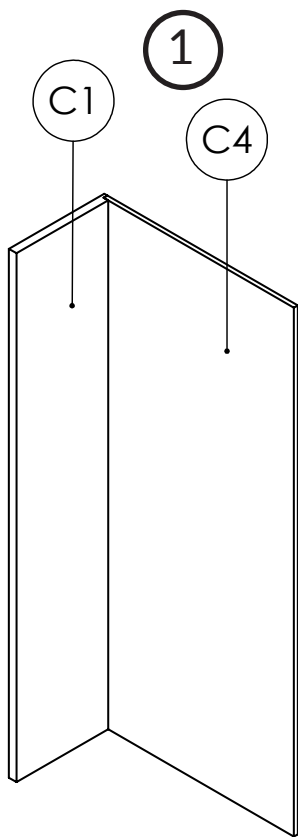

3

4

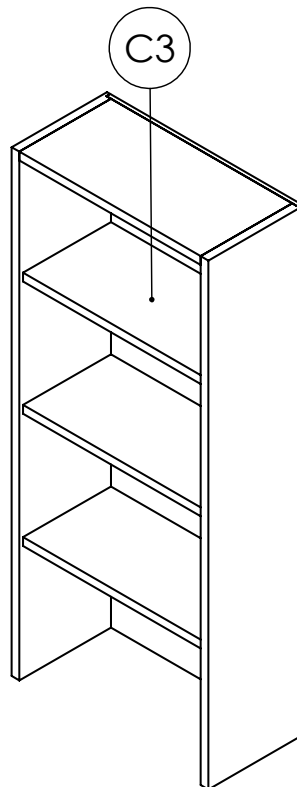
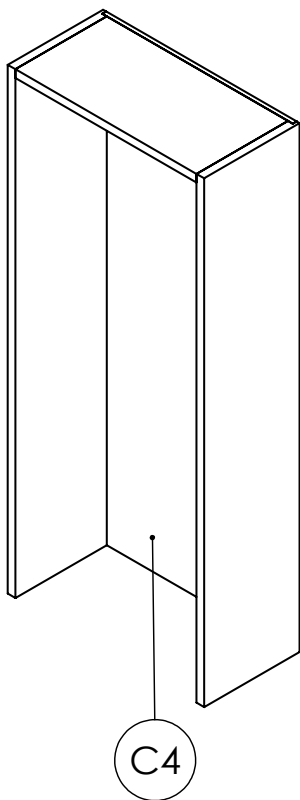

ANNEXE R
Meuble C - Pas à pas