

## Art libre

Copyleft Attitude

Cette notice est en licence libre, vous êtes libre de l'utiliser et de la modifier (voir modalités en dernière page), d'exercer votre esprit critique et de nous faire part de vos remarques constructives.

# Commode de télé

## TEMPS DE RÉALISATION

21 Heures

## COÛT INDICATIF

180 €

## DIFFICULTÉ



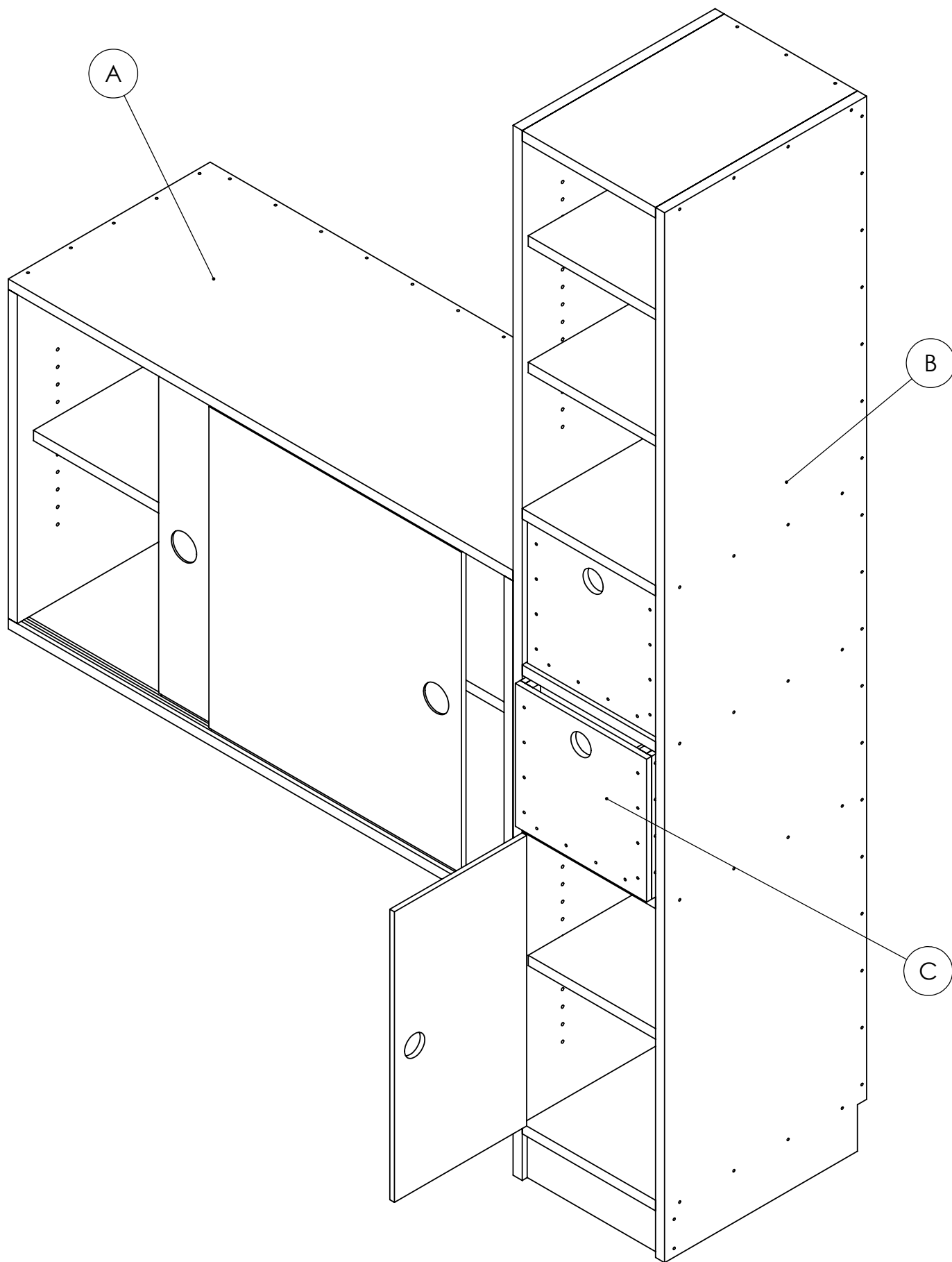

**ANNEXE A**  
Vue d'ensemble

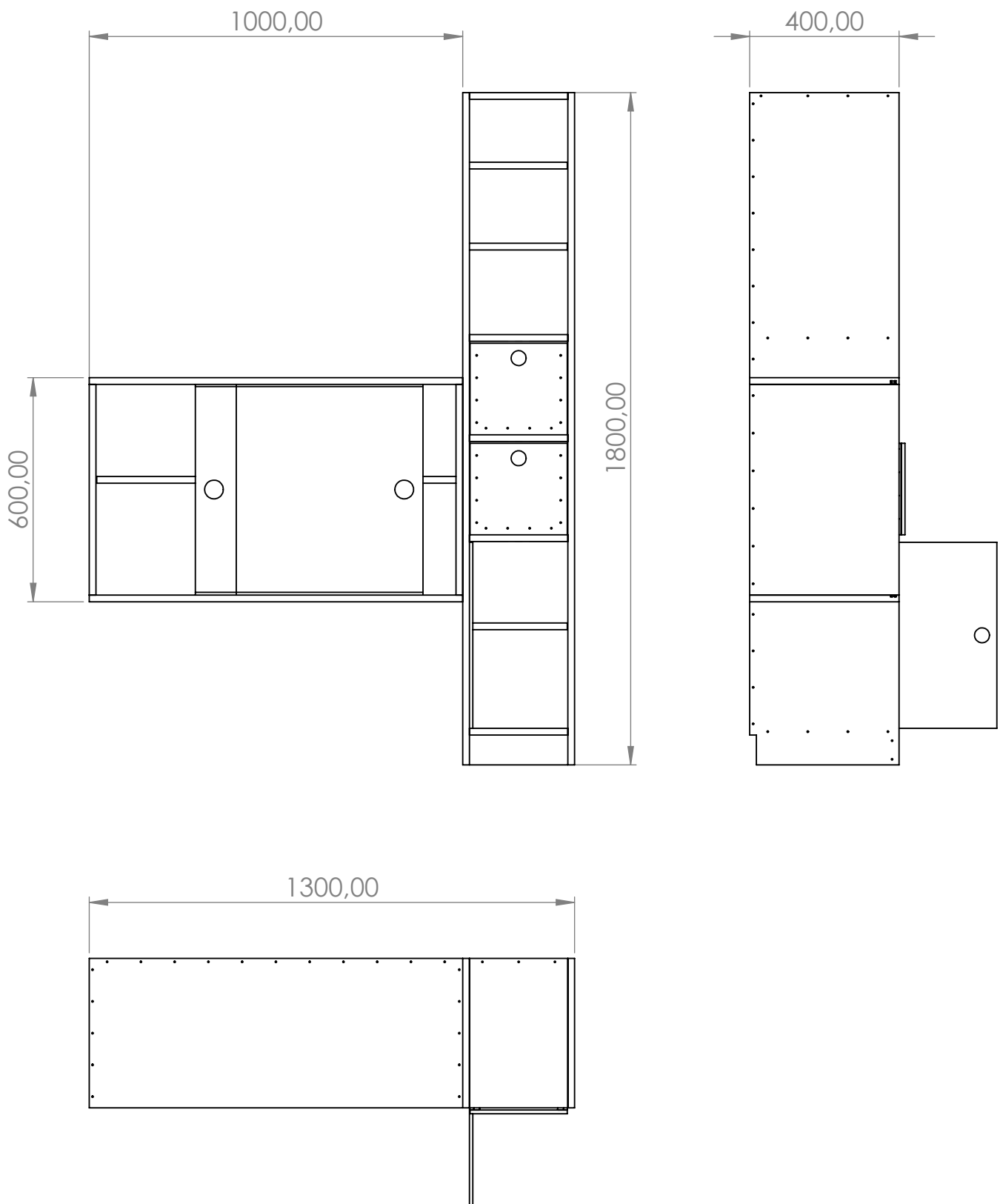

**ANNEXE B**  
Vue d'ensemble - Dimensions

Nombre	Nom des pièces	Matériaux	Description	Epaisseur (mm)	Largeur (mm)	Longueur (mm)	Commentaire
	<b>A</b>		<b>Meuble bas</b>				
2	A1	AggloméréStratifié	A1 Vertical	18	400	564	
2	A2	Contreplaqué	A2 horizontal	18	400	1000	cf vue de détail
1	A3	Aggloméré stratifié OU Contreplaqué	A3 Arrière	18	564	964	
1	A4	AggloméréStratifié	A4 Etagère	18	352	962	Amovible, système taquet
2	A5	Contreplaqué noir	A5 Porte	9	500	575	cf vue de détail

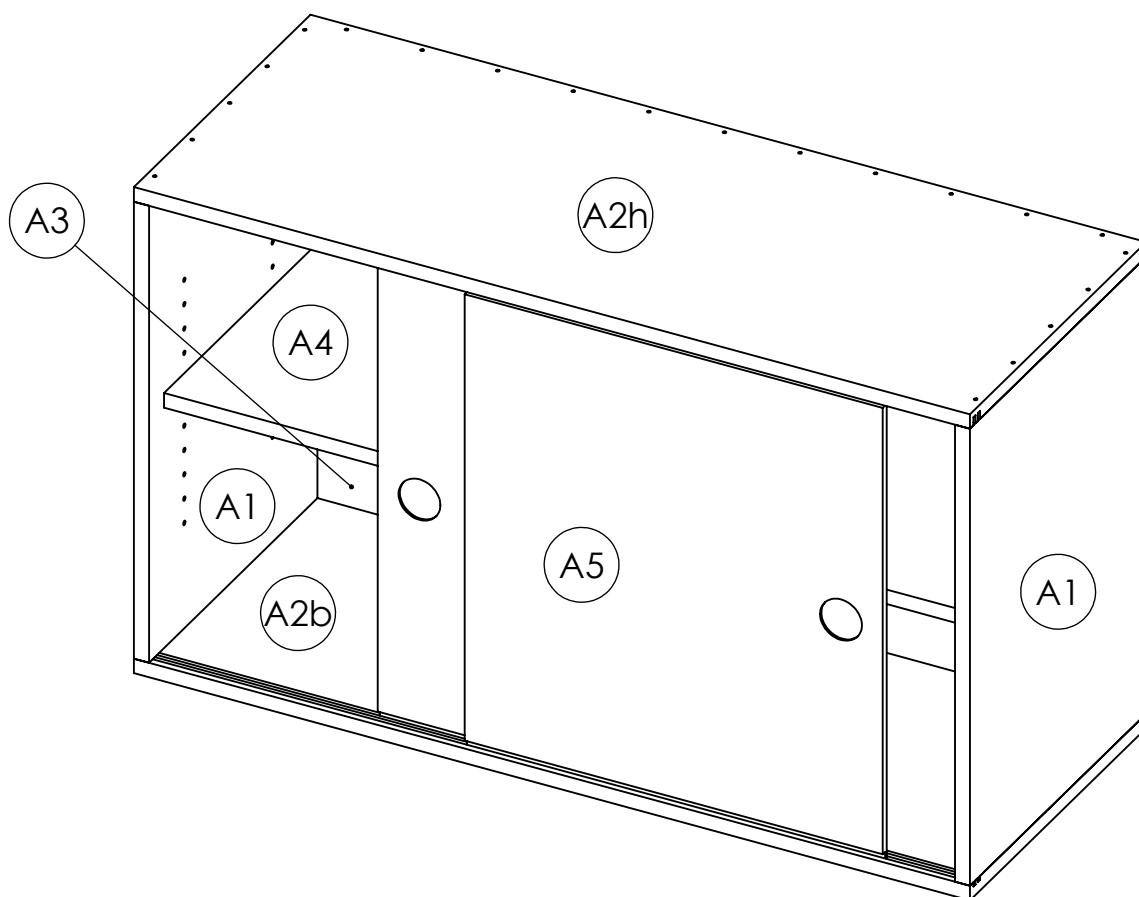

## ANNEXE C

### Meuble A - Nomenclature et élévation

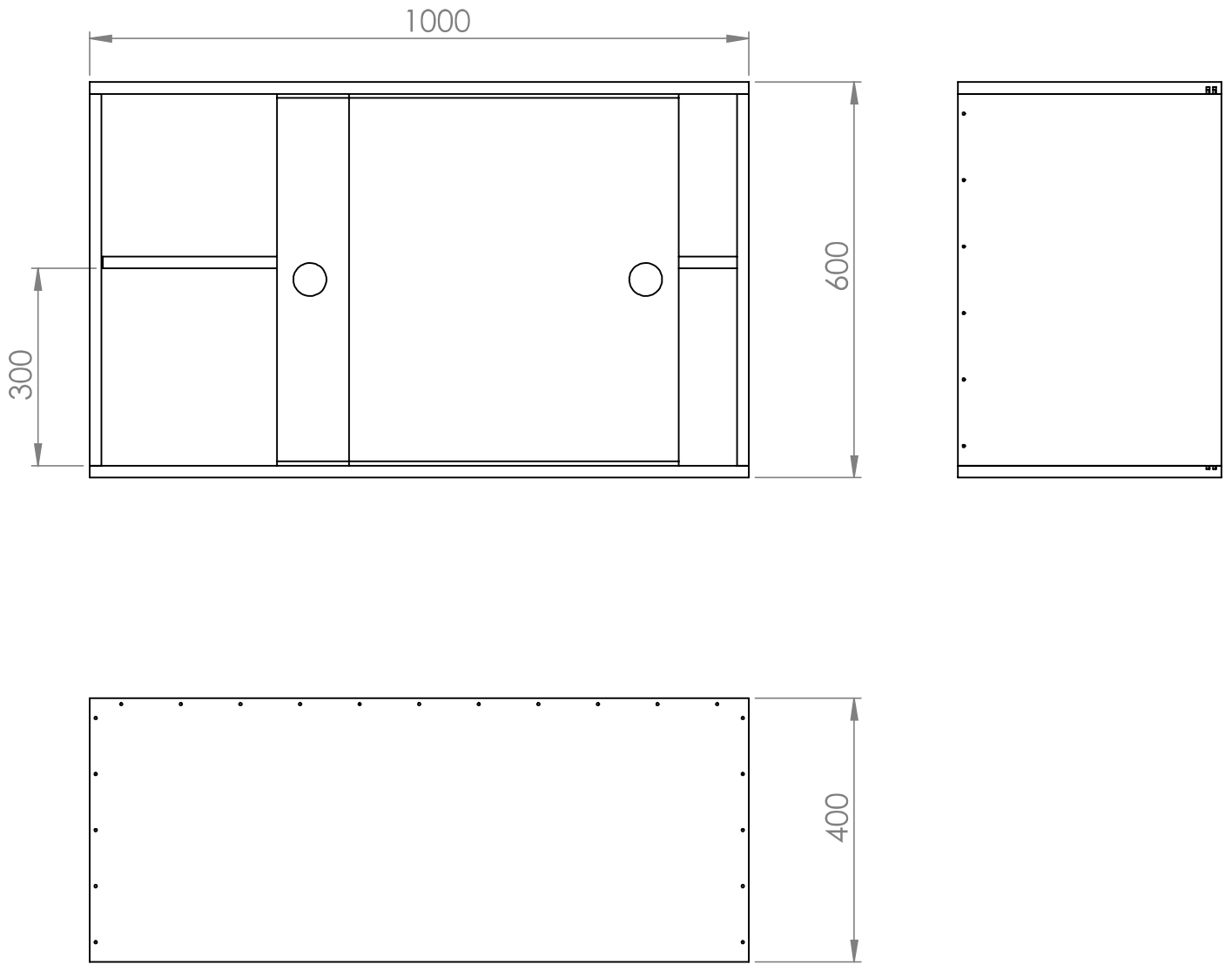

**ANNEXE D**  
Meuble A - Dimensions

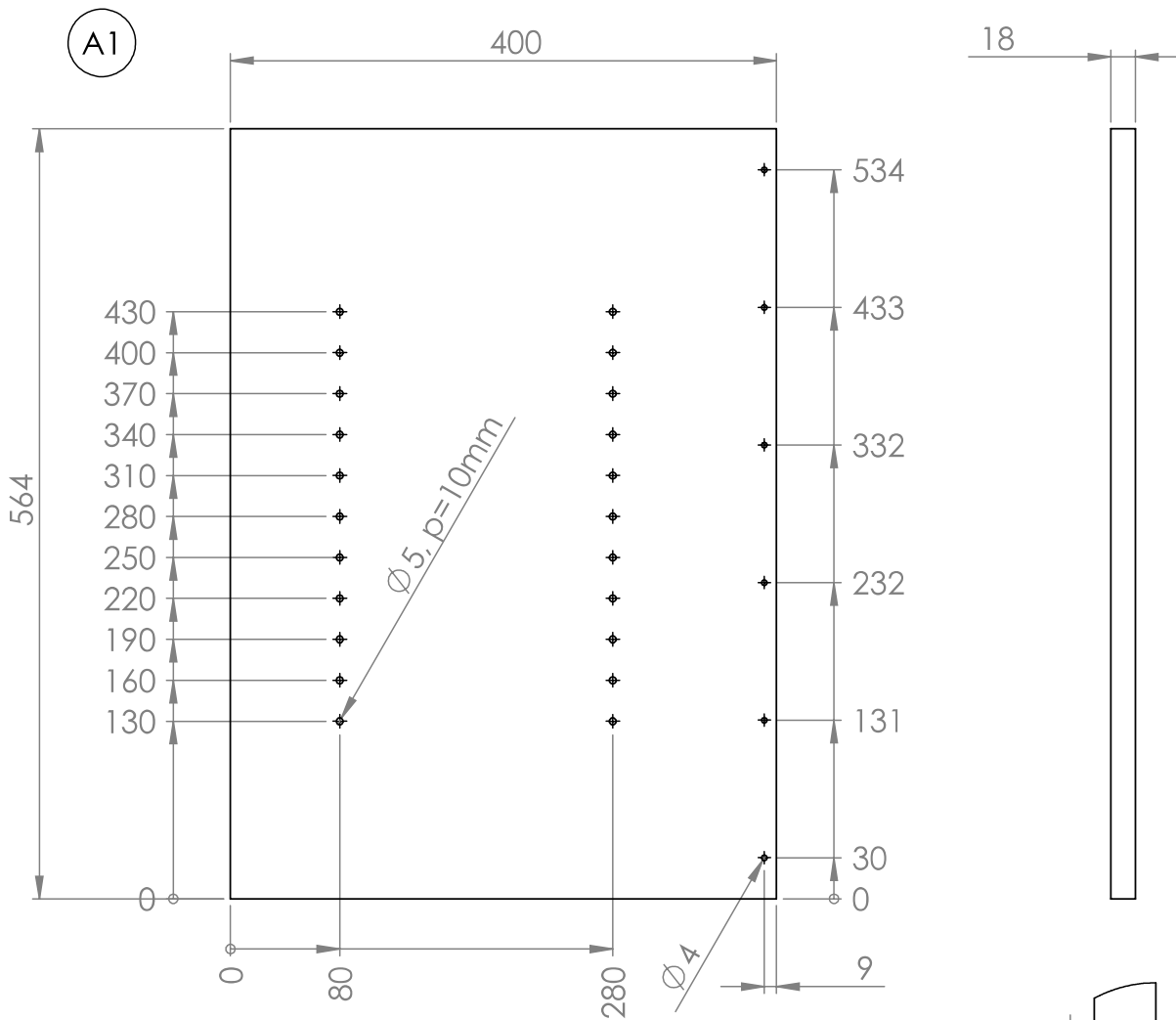

Attention, la profondeur de la rainure depend de la position de A2 :

- A2 bas -> 5mm
- A2 haut -> 10mm

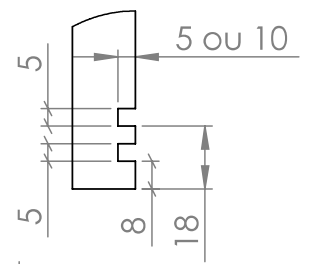

DÉTAIL A  
ECHELLE 1 : 2

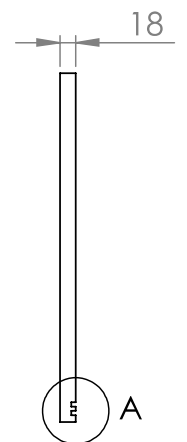
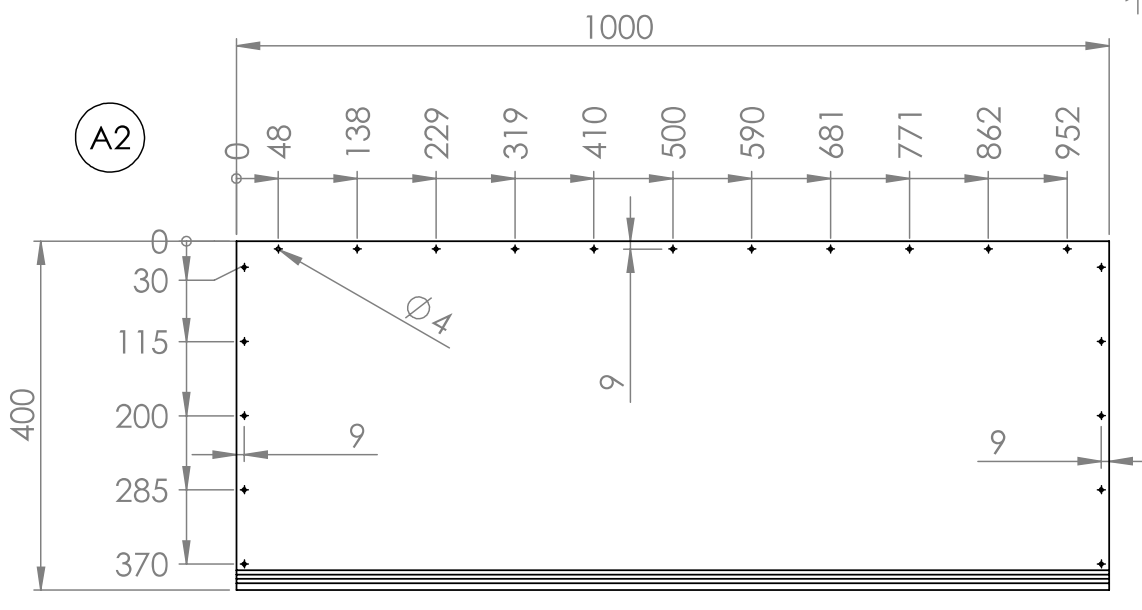

## ANNEXE E

### Meuble A - Pièces usinées

A5

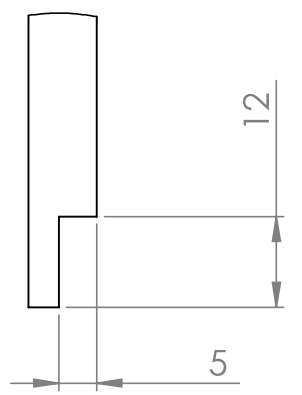
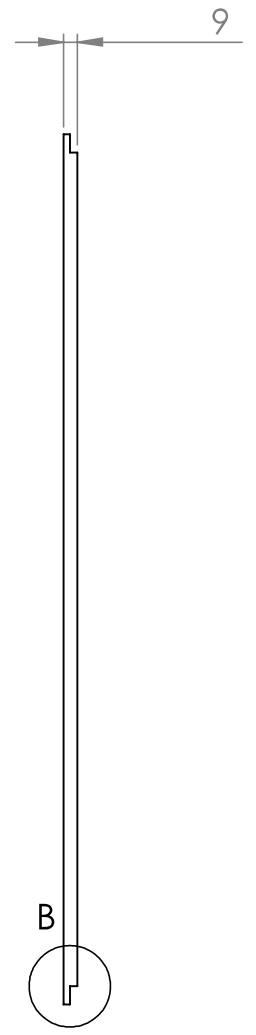
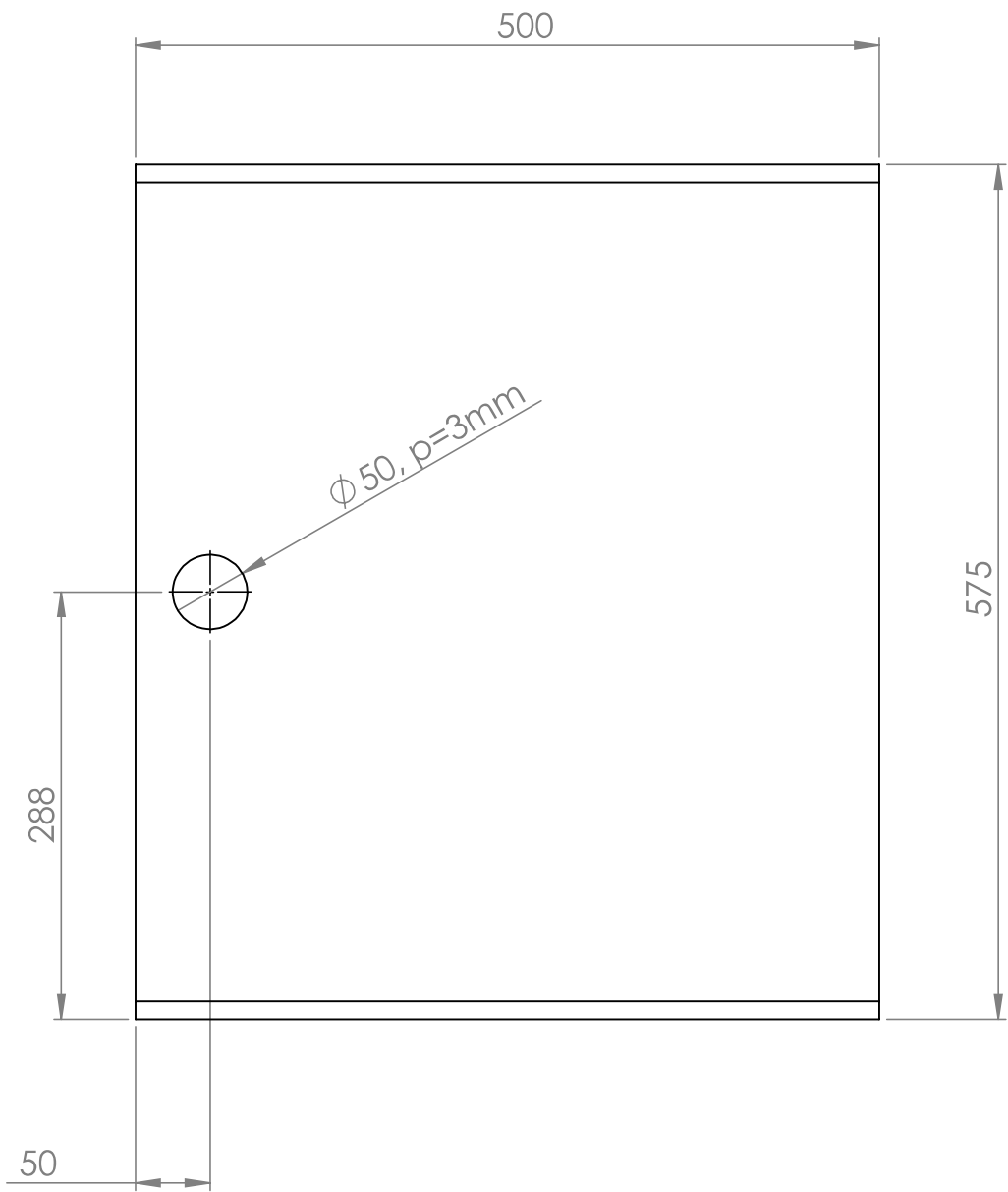

DÉTAIL B  
ECHELLE 1 : 1

**ANNEXE F**  
Meuble A - Pièces usinées

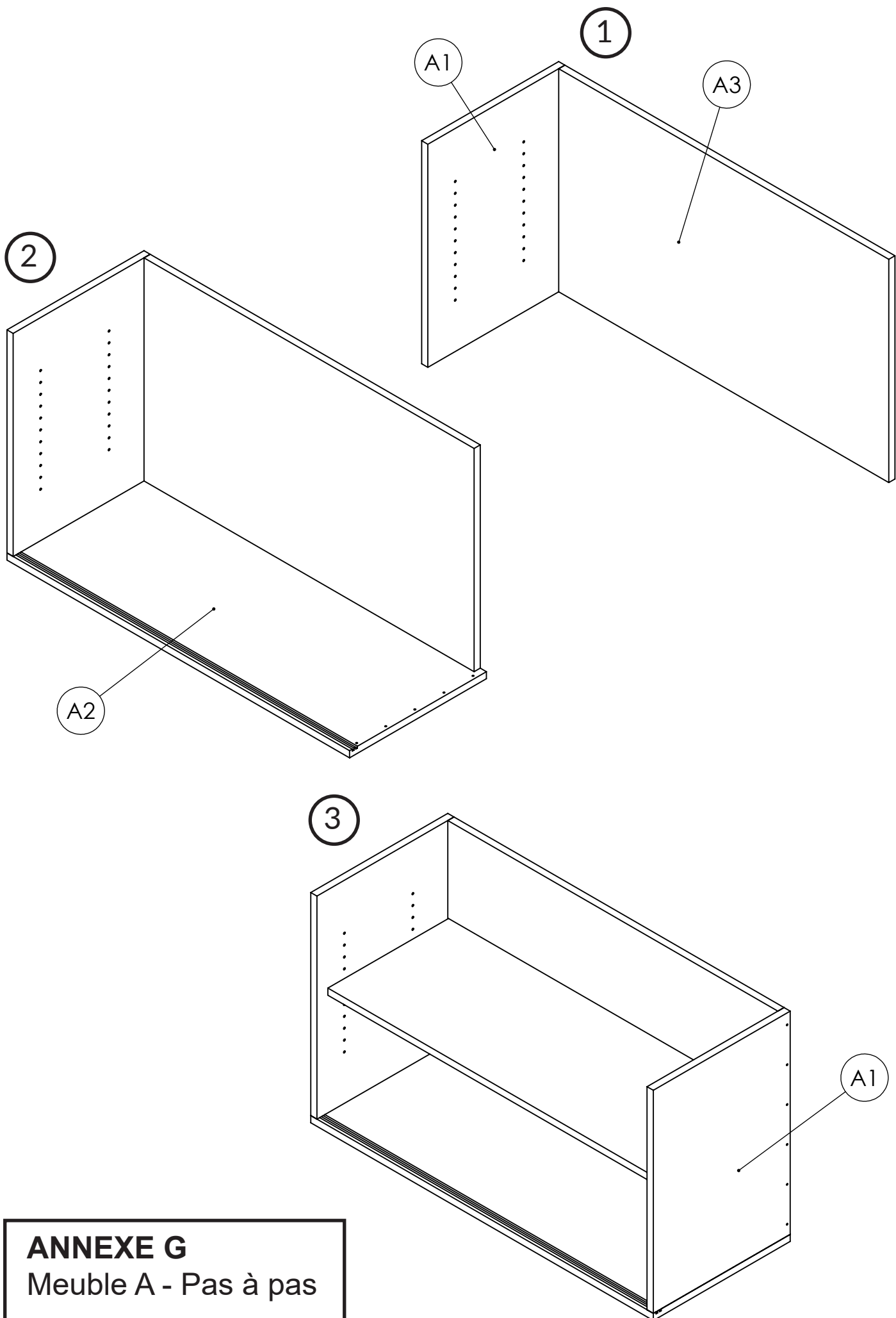

**ANNEXE G**  
Meuble A - Pas à pas



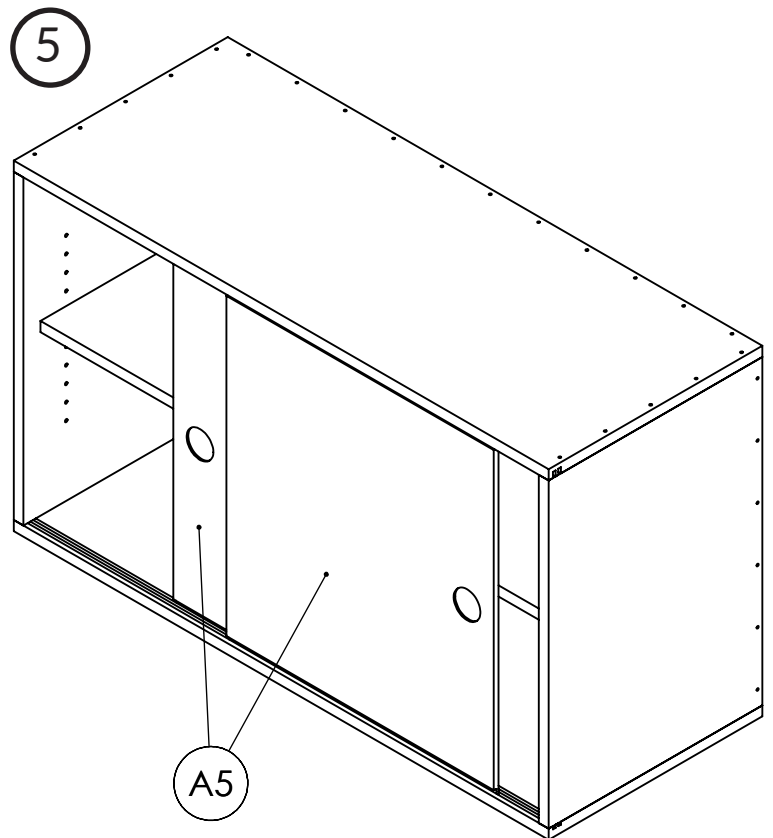
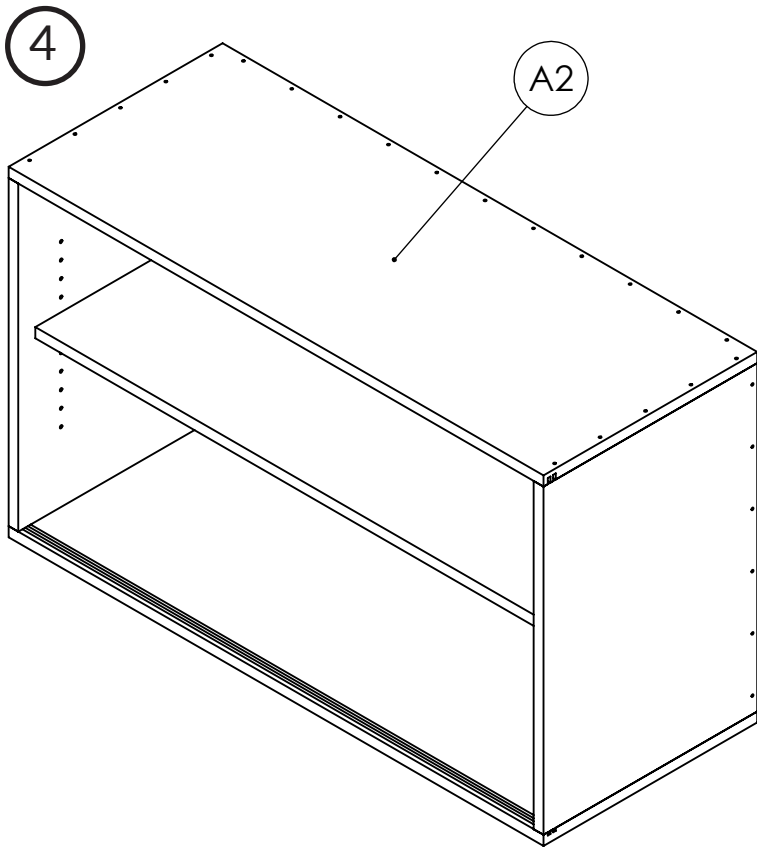

**ANNEXE H**  
Meuble A - Pas à pas

Nombre	Nom des pièces	Matériaux	Description	Epaisseur (mm)	Largeur (mm)	Longueur (mm)	Commentaire
	<b>B</b>		<b>Tour</b>				
2	B1		B1 Vertical	18	400	1800	Plinthe en bas
1	B2		B2 Arriere	18	264	1702	
1	B3		B3 Horizontal haut	18	264	400	
4	B4		B4 Etages fixes	18	264	382	
3	B5		B5 Etageres	18	262	370	Amovibles, système taquet
1	B6		B6 Plinthe	18	80	264	
1	B7	Contreplaqué noir	B7 Porte	mini. 15	262	498	Poignée fixée par charnières invisibles

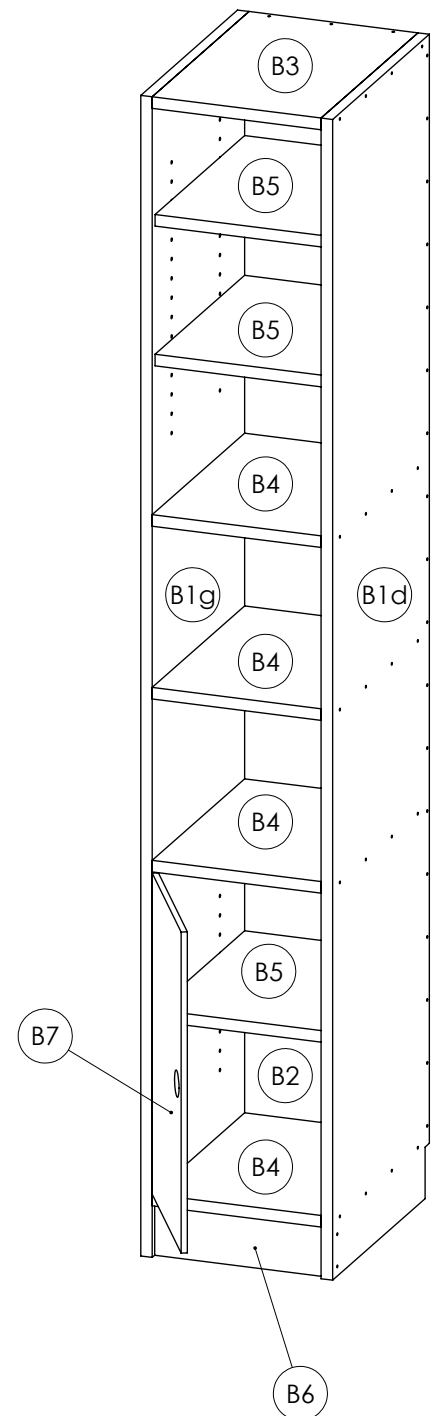
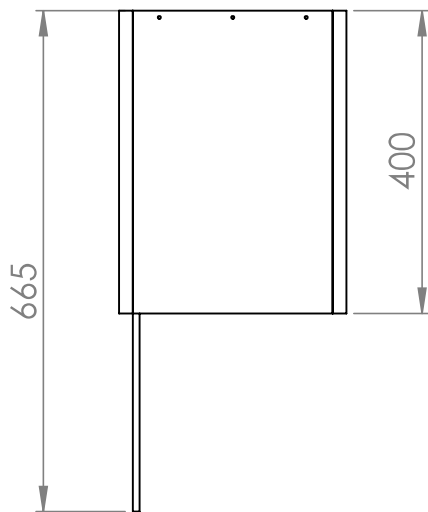

**ANNEXE I**  
Meuble B - Nomenclature et dimensions

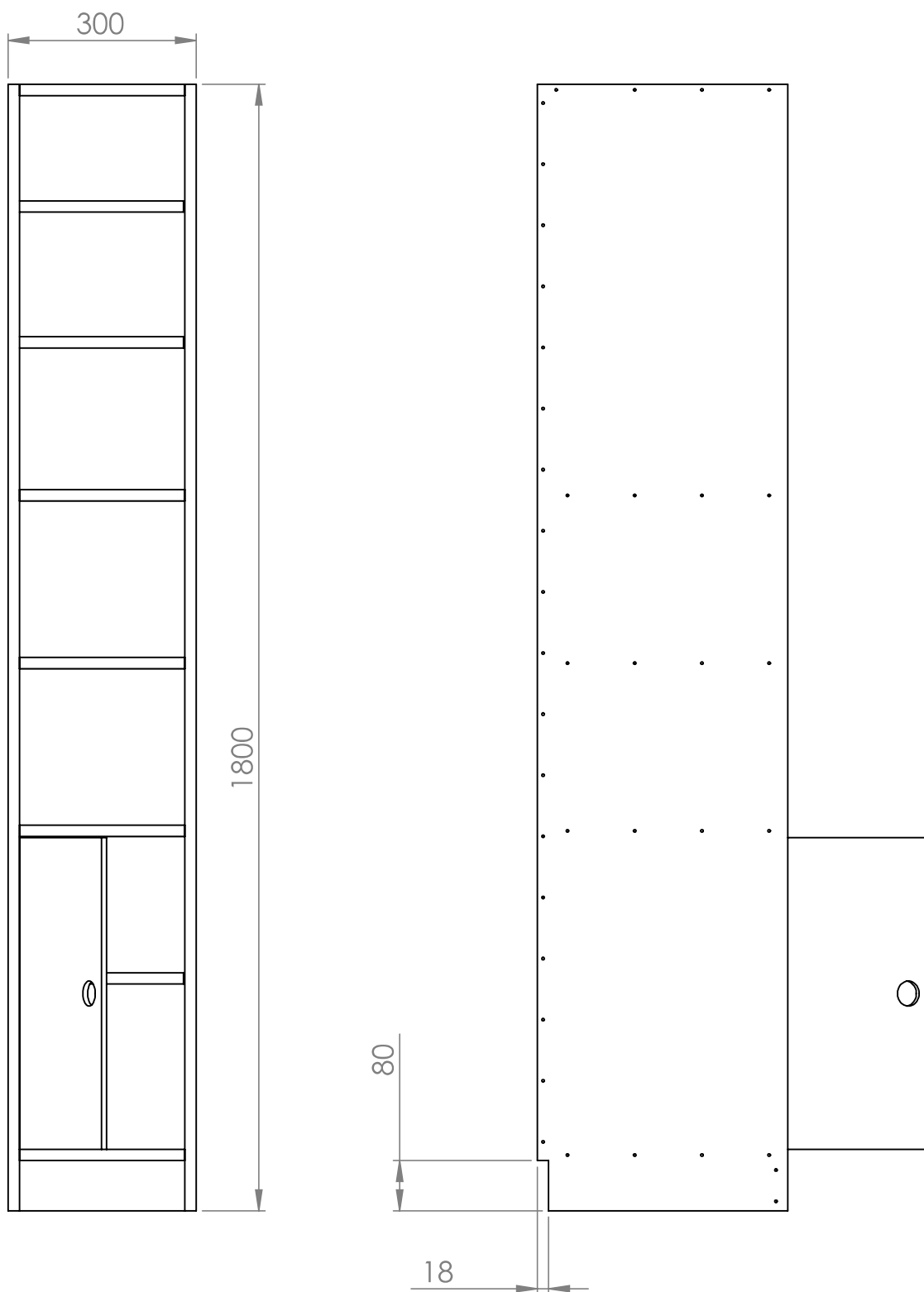

**ANNEXE J**  
Meuble C - Dimensions

B1

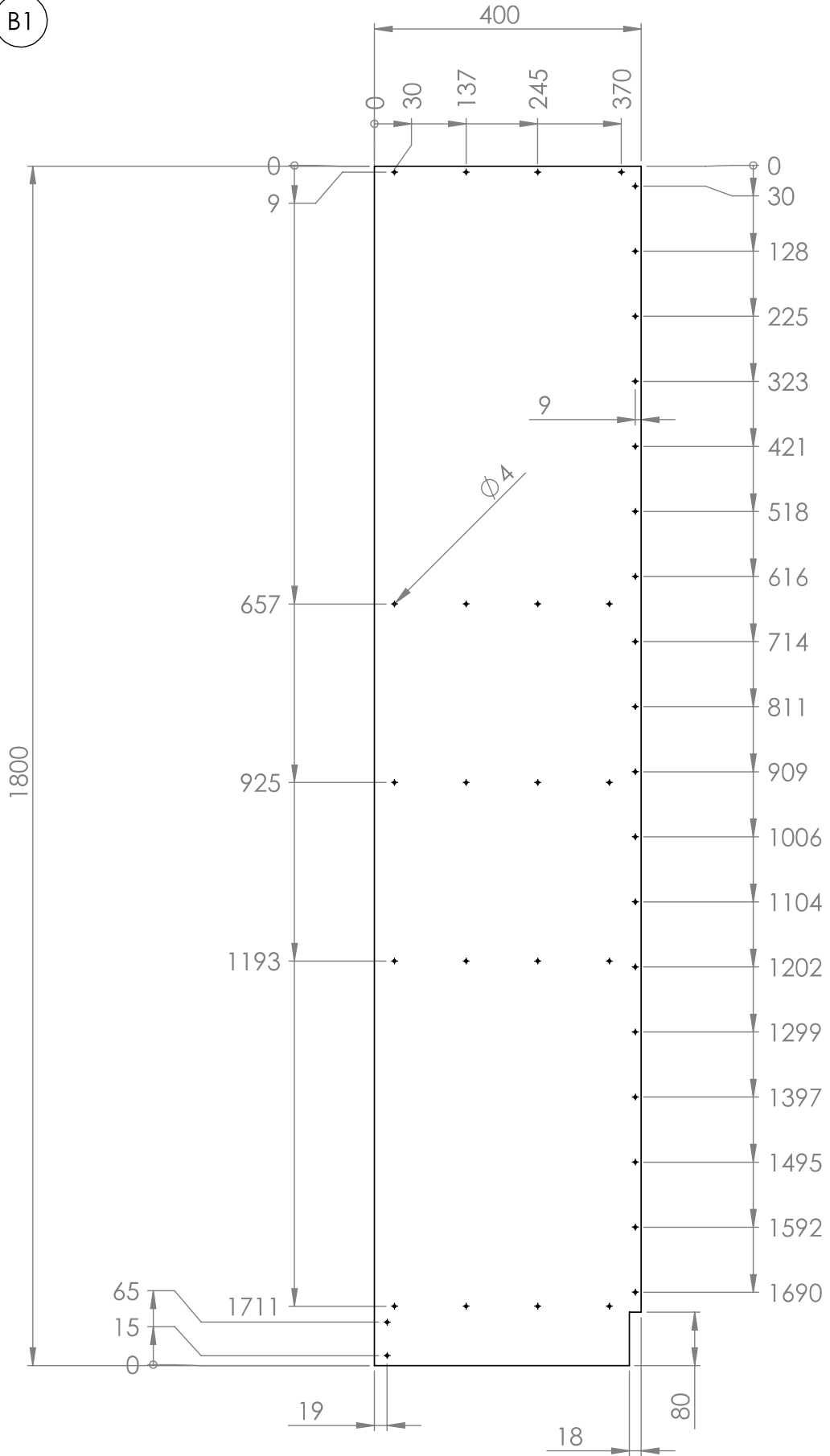

**ANNEXE K**  
Meuble B - Pièces usinées

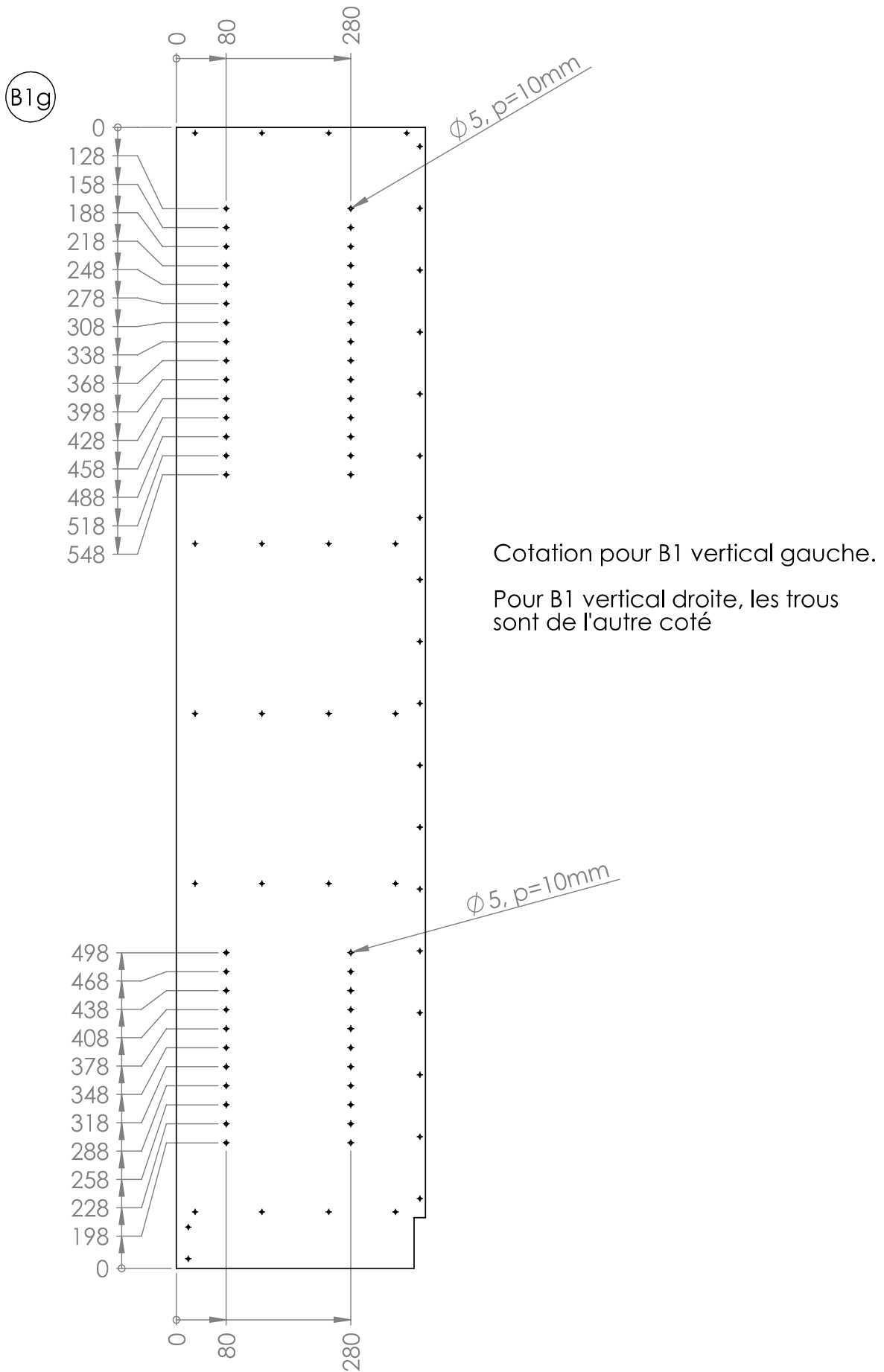

**ANNEXE L**  
Meuble B - Pièces usinées

B2

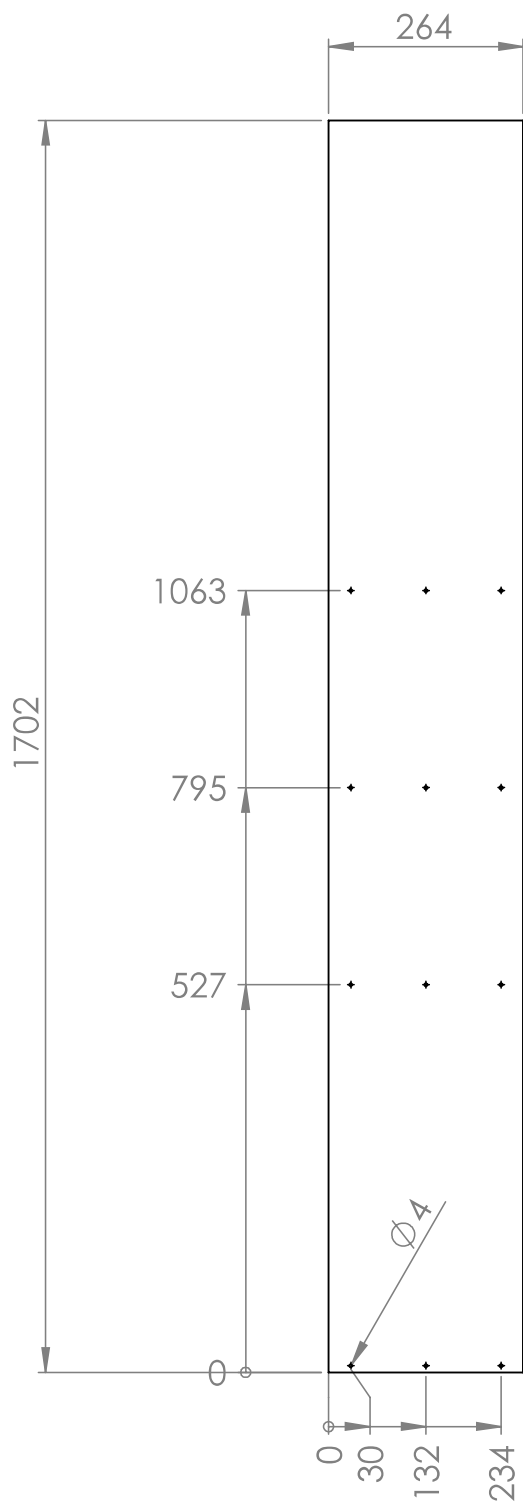

B3

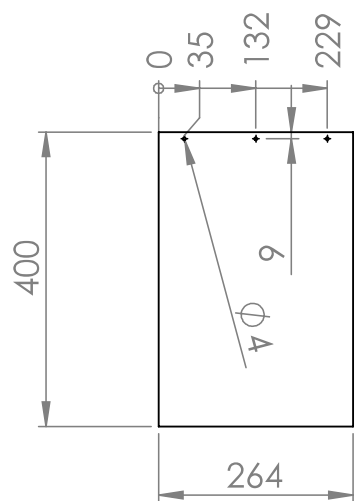

**ANNEXE M**  
Meuble B - Pièces usinées

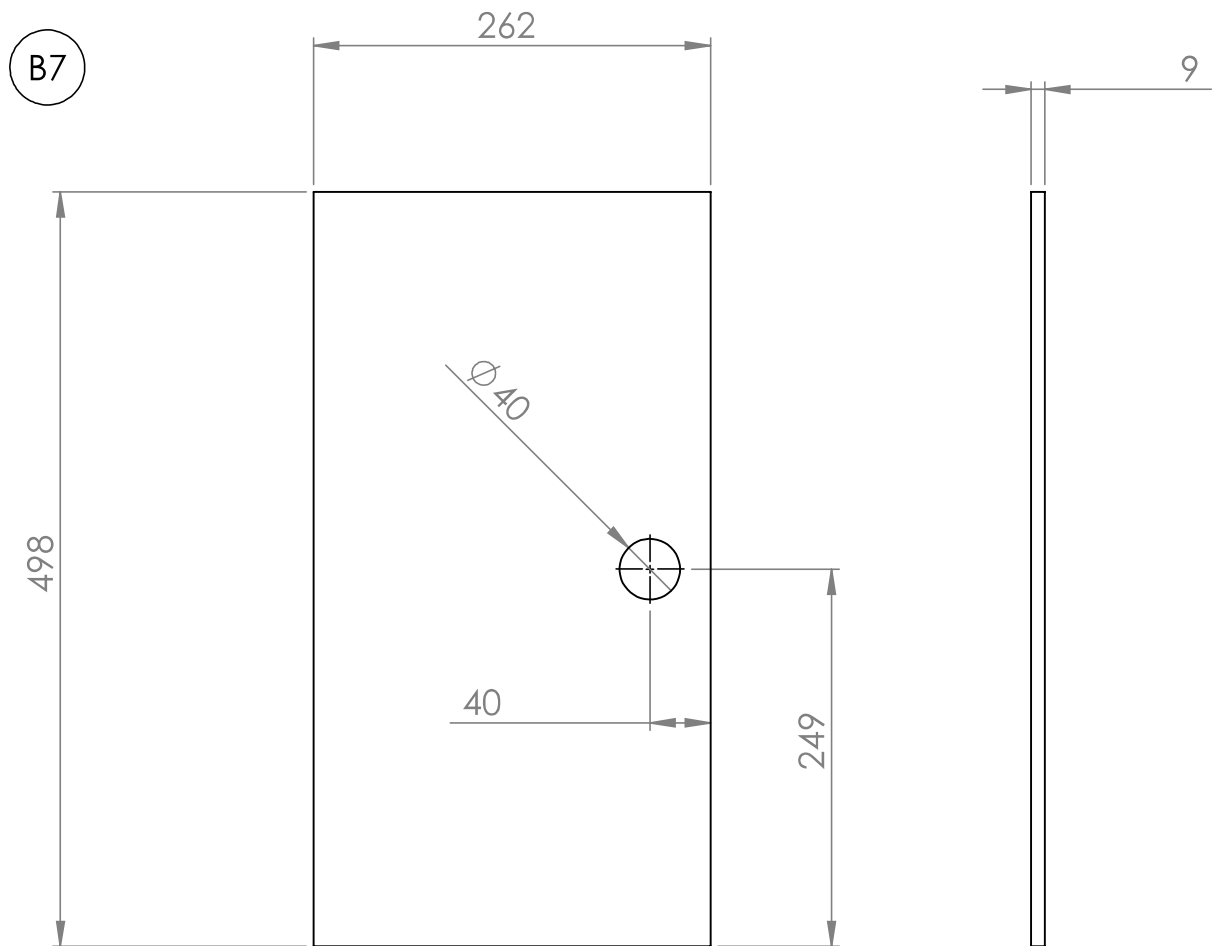

**ANNEXE N**  
Meuble B - Pièces usinées

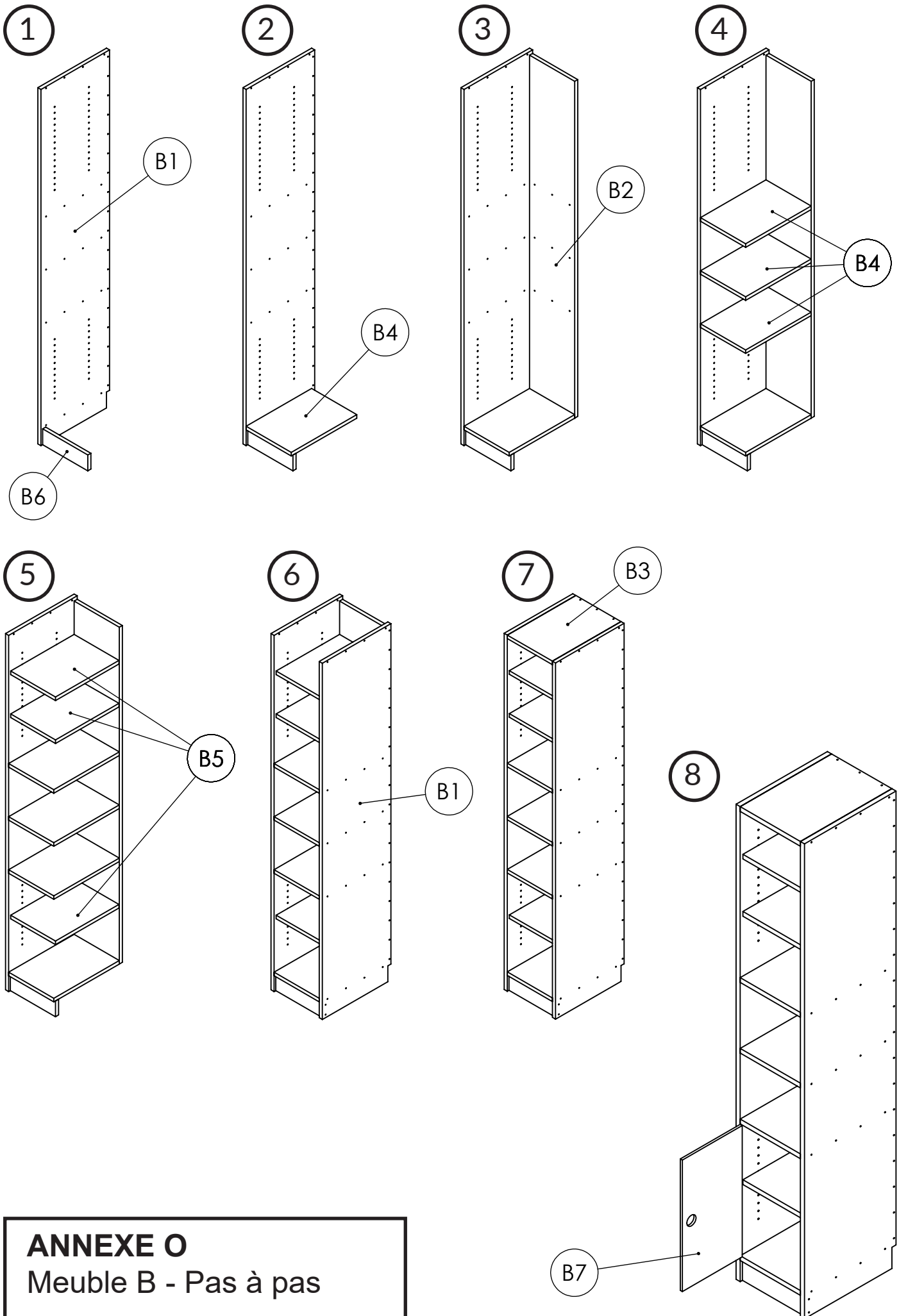

**ANNEXE O**  
**Meuble B - Pas à pas**



Nombre	Nom des pièces	Matériaux	Description	Epaisseur (mm)	Largeur (mm)	Longueur (mm)	Commentaire
	<b>C</b>		<b>Tiroirs (x2)</b>				
2	C1	Contreplaqué noir	C1 Avant-Arriere	10	245	260	Evidement circulaire poignée
2	C2	Contreplaqué	C2 Vertical	10	245	352	
1	C4	Contreplaqué	C4 Fond	10	240	352	
4	C5	Bois massif	C5 Tasseau vertical	15	15	234	Vissé
2	C6	Bois massif	C6 Tasseau avant arriere	15	15	208	Vissé
2	C7	Bois massif	C7 Tasseau cote	15	15	320	Vissé

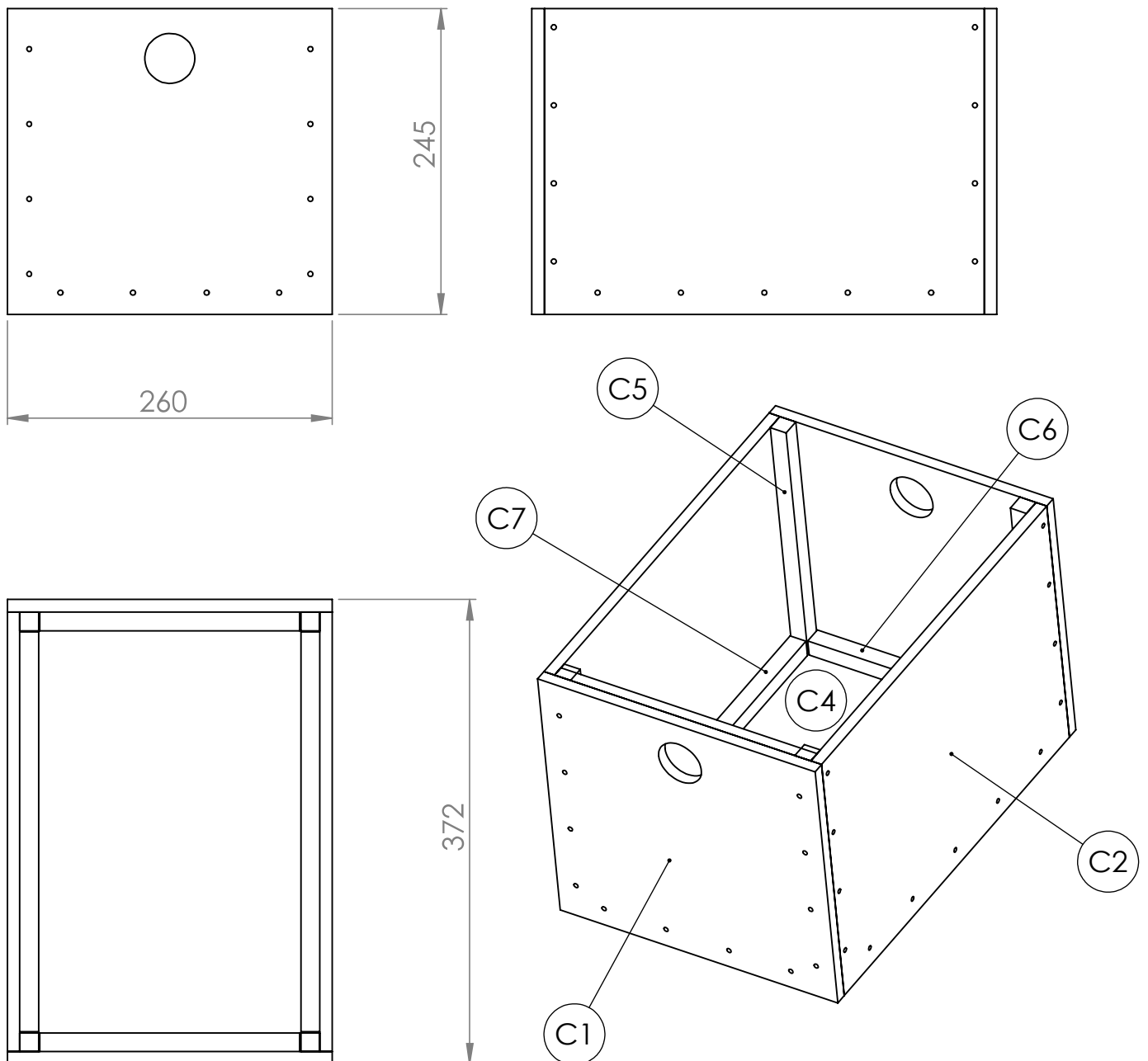

## ANNEXE P

### Meuble C - Nomenclature et dimensions



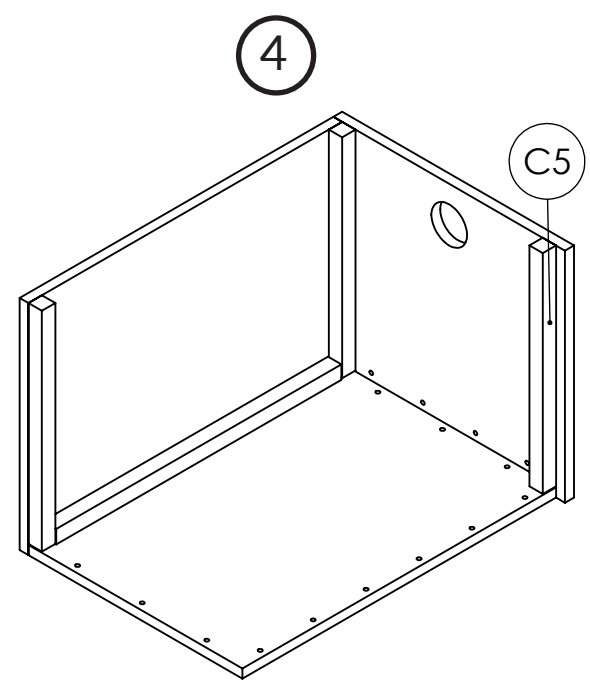
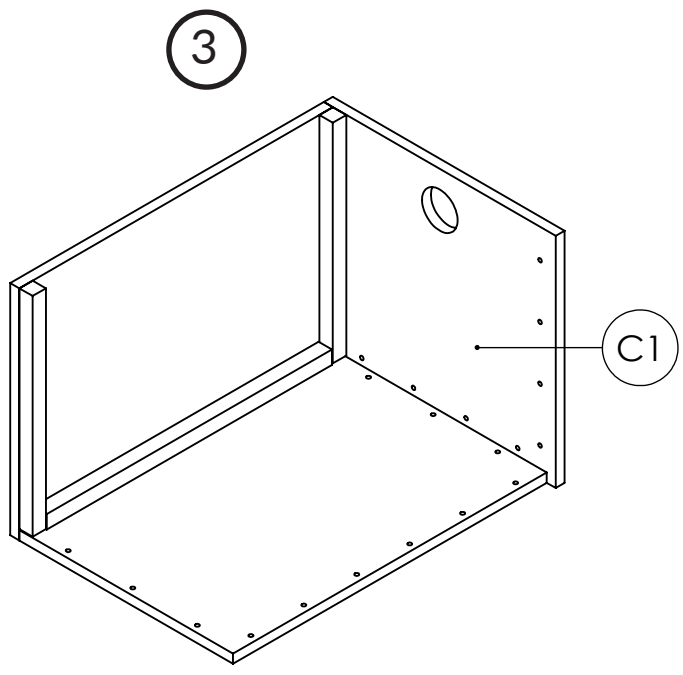
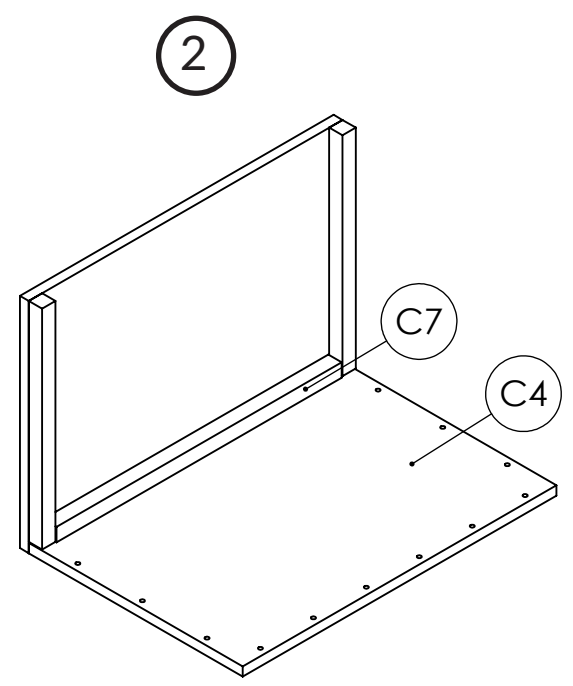
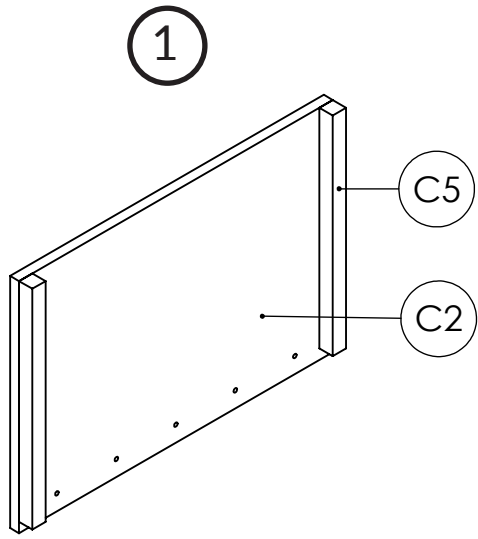

**ANNEXE R**  
Meuble C - Pas à pas

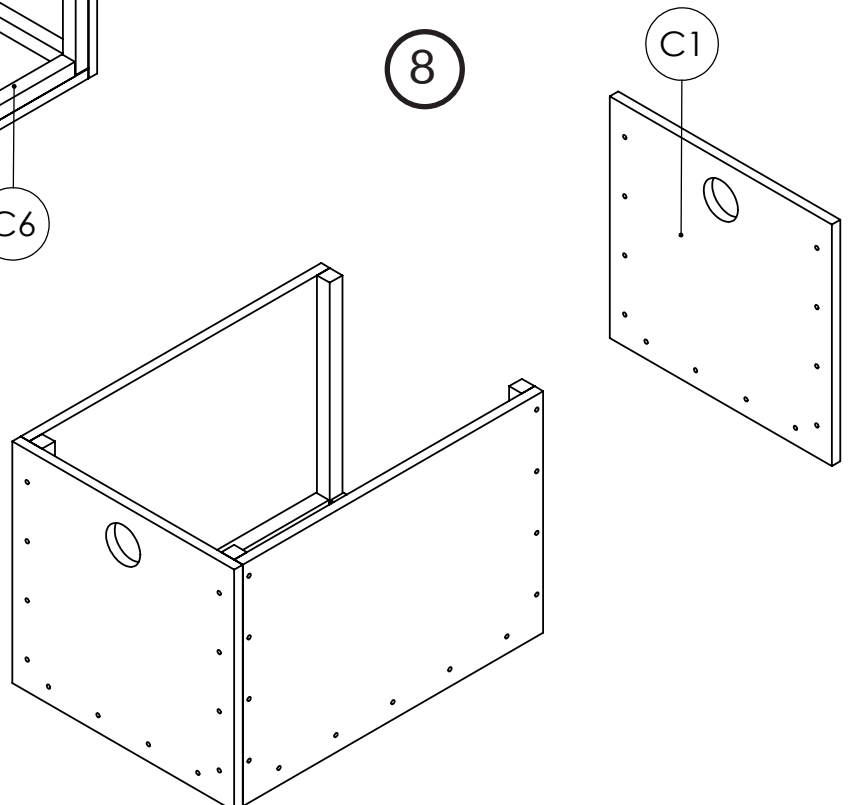
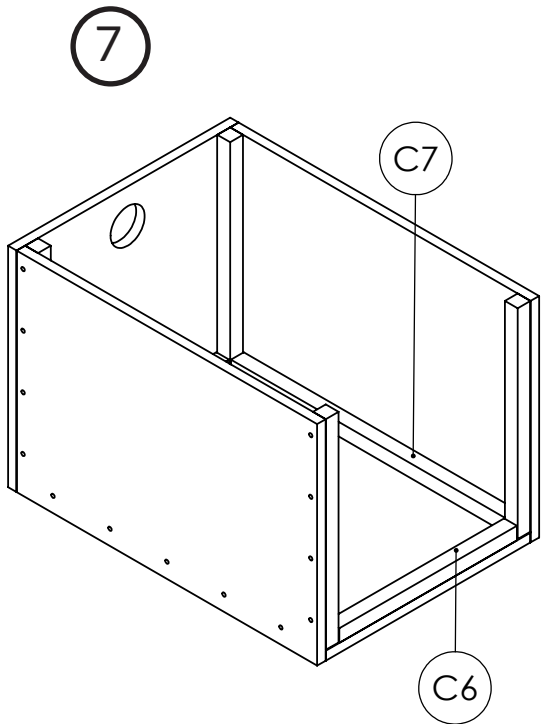
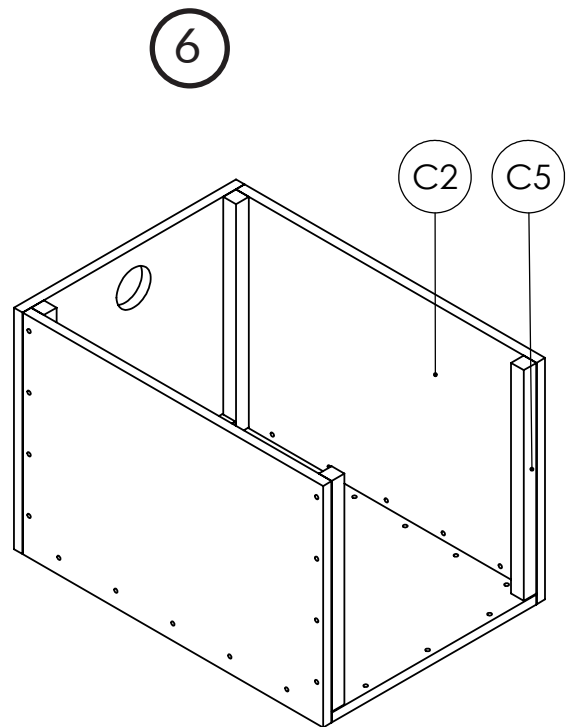
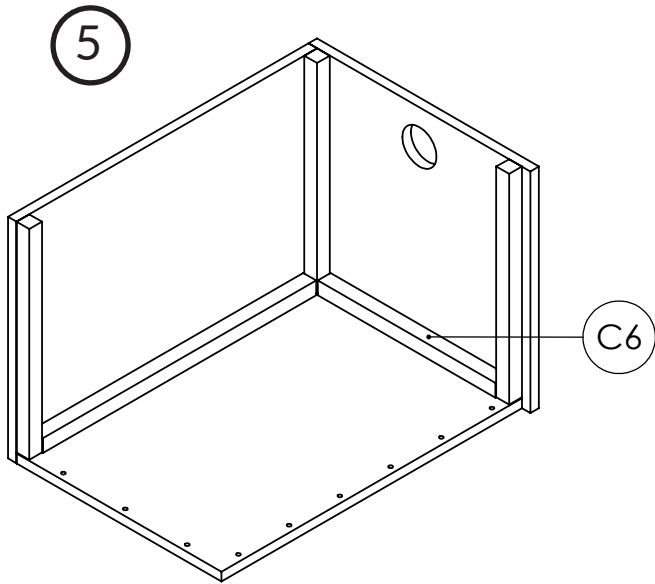

**ANNEXE Q**  
Meuble D - Pas à pas